

SHIELD[®]
TRUSTED WORLDWIDE



Fire Detection & Evacuation System 2019-2020

SHIELD[®]

TRUSTED WORLDWIDE



Introduction

Competence and innovation driven by consistent market development and customer requirements have shaped the successful development of the SHIELD Brand. The extensive product range of the market leader in the field of fire detection technology contains single, individually integrable system performances. In this way, a customized overall fire protection concept can be planned and realized for every need with optimally synchronized products.

Performance is in international demand, SHIELD is among the highly accredited fire alarm companies that meet rigorous British and American standards for all projects from small conventional system to multi site networks. Certifications such as UL and FM approvals have earned SHIELD a world-renowned reputation with quality products and powerful solutions.

A strong brand is generally known to be a secure basis for close and lasting customer relationships. In accordance with this, SHIELD uses available potential in order to keep on growing in a dynamic competitive environment. And at the same time, SHIELD stands for innovative and high quality fire alarm and evacuation systems.

We invite you to explore and visit our new website www.shieldglobal.com. You can also send us your feedback and inquiry through our user-friendly online forms.

In line with SHIELD policy for continuous product development, SHIELD has the right to change specifications without prior notice. Images shown in this catalogue are for illustrations purposes only.

Contents

1	Certificates Overview	1-2
2	Addressable Fire Detectors and Standard Bases	3-6
	Photo-Electric Smoke Detector	4
	Heat Detector	4
	Multisensor	5
	Mounting Base	5
	E-Z Fit Base	6
3	Special Addressable Bases	7-8
	Low Power Relay Base	8
	Isolating Base	8
4	Conventional Fire Detectors and Base	9-12
	Photo-Electric Smoke Detector	10
	Heat Detector (135°F / 57°C)	10
	Heat Detector (170°F / 77°C)	11
	Heat Detector (200°F / 93°C)	11
	Standard Mounting Base	12
5	Interconnected Detectors (9V DC & 230V AC)	13-16
	Heat Detector	14
	Smoke & Multi Detector	15
6	Beam Detector	17-20
	Alpha 1000 Reflective Beam Detector	18
	Alpha 3000 End to End Beam Detector	19
	Alpha 5000 Auto Align Beam Detector	20
7	Addressable Modules	21-26
	Mini Monitor Module	22
	Dual Priority Switch Monitor Module	22
	Switch Monitor Module	23
	Switch Monitor Input/Output Module	23
	Sounder Control Module	24
	Isolator Module	24
	Mini Priority Switch Monitor Module	25
	Mini Switch Monitor Module	25
	120V AC Input/Output Module	26
	Relay Output Module	26

8	Addressable Notification Devices	27-30
	Open-Area Sounder	28
	Open-Area Sounder Beacon	29
	Sounder Beacon Base (For Detectors)	30
9	Addressable Pull Stations	31-32
	Dual Action Pull Station	32
10	Addressable Fire Detection System	33-44
	OMEGA Addressable Fire Alarm Control Panel	34
	OMEGA-X Addressable Fire Alarm Control Panel	36
	OMEGA-R Repeater Panel	38
	Graphical User Interface for Fire Detection Equipment	40
	Gateway for Integration with Building Management System	42
11	Extinguishant Control System	45-48
	Extinguishant Control Panel	46
	Abort Switch	48
12	Voice Evacuation System	49-54
	Master and Distributed Panel	50-52
	Fire Phone Equipment	53
	Fire Phone Storage Cabinet	54
	Fire Fighter's Portable Handset & Fire Fighter's Jack	54
13	Voice Evacuation Speakers	55-57
	Ceiling Speaker and Wall Speaker	56

Certificates Overview



CERTIFICATE



This is to certify that



Shield Fire, Safety and Security Limited
 Redburn House
 2A Tonbridge Road
 Romford
 Essex RM3 8QE
 United Kingdom

has implemented and maintains a **Quality Management System**.

Scope:
 Manufacture, Assembly & Testing of Grooved and Threaded Pipe Fittings, and Valves for Fresh Water/Sea Water and Fire Fighting Equipment. The Testing and Assembly of ERW & Seamless Pipes.

Through an audit, documented in a report, it was verified that the management system fulfills the requirements of the following standard:

ISO 9001 : 2015

Certificate registration no. 20005627 0M15
 Date of original certification 2014-09-09
 Date of certification 2016-10-25
 Valid until 2019-10-24



DQS Inc.

 Ganesh Rao
 Managing Director

Accredited Body: DQS Inc., 1138 West Lake Cook Road, Suite 340, Buffalo Grove, IL 60089 USA
 Administrative Office: Deutscher Quality Systems (India) Pvt. Ltd., 5th Floor, Ananya Techno Park, 147, Hill Airport Road, Kothahalli, Bangalore - 560 017 - India





UOJZ.S25191

Control Units, System

See General Information for Control Units, System

SHIELD FIRE SAFETY & SECURITY LTD
 REDBURN HOUSE
 2A TONBRIDGE ROAD
 ROMFORD, ESSEX RM3 8QE UNITED KINGDOM

S25191

UL 864 9th Edition Listed

Model	Control Unit System Type(s)	Initiating Device Type(s)	Signaling Type(s)
"SHIELD A-XT"			
S115G-EXT	L	A, M	-
S115R-EXT, S230R-EXT	L	A, M	-
S230G-EXT	L	A, M	NC
SA-P20R0, SA-P20R3, SA-P20G0, SA-P20G3, SA-P2ER0, SA-P2ER3, SA-P2EG0, SA-P2EG3, SA-P4LR0, SA-P4LR3, SA-P4LG0, SA-P4LG3, SA-P4ER0, SA-P4ER3, SA-P4EG0, SA-P4EG3			
	RS (PPU)	A, M, SS, WF	DAC
	P (PPU)	A, M, SS, WF	C, MX, NC, OT
	CS (PPU)	A, M, SS, WF	DAC, MX, OT
	L	A, M, SS, WF	March, NC
	AUX	A, M, WF	NC
SI-90	L	A, M, SS, WF	C, March, NC
SI-90/MB	L	A, M, SS, WF	March, NC
SR-P10R, SR-P10G, SR-P1NR, SR-P1NG, SR-P1ER, SR-P1EG, SR-P1DR, SR-P1DGR, SR-P1NDR, SR-P1NDGR, SR-P1EIDR, SR-P1EIDG, SR-P2LR, SR-P2LG, SR-P2ER, SR-P2ELG, SR-P2IDLR, SR-P2IDLG, SR-P2EIDLR, SR-P2EIDLG			
	L	A, M, SS, WF	March, NC
	AUX	A, M, SS, WF	NC
	RS (PPU)	A, M, SS, WF	DAC, OT
	P (PPU)	A, M, SS, WF	C, MX, NC, OT
	CS (PPU)	A, M, SS, WF	DAC, MX, OT

UL 864 9th Edition Listed

Subassembly, Model(s) SI-2302-1, SI-2401-1, SI-2402-1, SI-2403-1, SI-2501-1, SI-2502-1, SI-2503-1, SI-2504-1, SI-2601-1, SI-2701-1, SI-2702-1, SI-2804-1, SI-3807-2, SI-3901-1, SI-3902-1, SI-3903-1, SI-3904-1, SI-3905-1

Model(s) SI-20R-0

Detection and Release Panel



UOXX.S25368

Control Unit Accessories, System

Page Bottom

Control Unit Accessories, System

See General Information for Control Unit Accessories, System

SHIELD FIRE SAFETY & SECURITY LTD
 REDBURN HOUSE
 2A TONBRIDGE ROAD
 ROMFORD, ESSEX RM3 8QE UNITED KINGDOM

S25368

Audio adjunct systems Model(s) SHX-100, SHX-100E, SHX-150, SHX-150E, SHX-200, SHX-200E, SHX-25, SHX-25E, SHX-300, SHX-300E, SHX-400, SHX-400E, SHX-50, SHX-50E, SHX-500, SHX-500E, SHX-600, SHX-600E, SHX-DP, SHX-MP

Fire Alarm Subassembly Model(s) MFP Master Fire Phone Card®, DCC Data Communications Control Card, ASC Audio System Control Card®, SSC Switch Scan Card®, MMC Microphone Master Control Card®, I/O Input/Output Card®, SLC Switch and LED Card®, MPH Master Fire Phone Handset Card®, MX-PWR Power supply®, MBR Motherboard Card®, AMI Audio Module Interface Card®, FFS Fire Phone Interface Card®, MBK Motherboard/Relay Card®, SH-BRK Breakout card for ribbon cables®, SH-LLC LED Annunciator card®, SH-FO Fiber Optic Transceiver®, SH-BK-100 Backup Amplifier Switcher®, SH-ISO Serial Port Isolator®

SH-SC

Fireman's Handset Model(s) SH-FH

Fireman's phone jacks Model(s) SH-FJ

Fireman's telephone stations Model(s) SH-FS

Input/Output Module Model(s) S-A4049

Isolator modules Model(s) S-A4002 (Base), S-A4051 (Isolator)

Main enclosures Model(s) SH-CAB2

Mini monitor modules Model(s) S-A4041

Remote microphones Model(s) SH-RM

Surface enclosures Model(s) SH-CAB3



Switch monitor modules Model(s) S-A4042, S-A4043, S-A4044, S-A4045, S-A4046, S-A4047, S-A4048

Telephone storage cabinets Model(s) SH-TC

Warden's telephone stations Model(s) SH-W5

XP95A relay output modules Model(s) S-A4050

@ - Subassemblies for use with the Model HMX System

Trademark and/or Tradename:  **SHIELD**,  **SHIELD**

Last Updated on 2016-05-04

Questions? [Print this page](#) [Terms of Use](#) [Page Top](#)

© 2016 UL LLC

The appearance of a company's name or product in this database does not in itself assure that products so identified have been manufactured under UL's Follow-Up Service. Only those products bearing the UL Mark should be considered to be Certified and covered under UL's Follow-Up Service. Always look for the Mark on the product.

UL permits the reproduction of the material contained in the Online Certification Directory subject to the following conditions: 1. The Guide Information, Assemblies, Constructions, Designs, Systems, and/or Certifications (files) must be presented in their entirety and in a non-misleading manner, without any manipulation of the data (or drawings). 2. The statement "Reprinted from the Online Certifications Directory with permission from UL" must appear adjacent to the extracted material. In addition, the reprinted material must include a copyright notice in the following format: "© 2016 UL LLC".

Voice Evacuation Panel



UROX.S25422

Smoke-automatic Fire Detectors

Page Bottom

Smoke-automatic Fire Detectors

See General Information for Smoke-automatic Fire Detectors

SHIELD FIRE SAFETY & SECURITY LTD
 REDBURN HOUSE
 2A TONBRIDGE ROAD
 ROMFORD, ESSEX RM3 8QE UNITED KINGDOM

S25422

Detector	Model	Application	Type	Compatibility Restrictions	Velocity Range (ft/m)		Date of Manufacture	Time of Manufacture	Firmware Version	Firmware Update
					Min	Max				
Alpha 3000(b)	OAP	PB	None							
Alpha 5000	OAP	PB	None							
S-A4011	OAP	P	D1	0	300					
S-A4012	OAP	I	D1	0	300					
S-A4014	OAP	P(HD)	D1	0	300					
S-C1050	OAP	PB	None							
S-C1100	OAP	PB	None							
S-C2011(d)	OAP	P	D2	0	300					
S-C2012 (c)	OAP	I	D2	0	300					

Base Model	Related Detector	Control Unit Compatibility Restrictions
S-A4001, S-A4003, S-A4004, S-A4007	S-A4012, S-A4011, S-A4014	B2
S-A4005, S-A4006	S-A4012, S-A4011, S-A4014	B2
S-A4008	S-A4011, S-A4012, S-A4013, S-A4014	B2
S-A4023, S-A4024	S-A4012, S-A4011, S-A4014	B2
S-C2001	S-C2011(d), S-C2012 (c)	B2

B2 - For connection to Listed control units with which compatibility was determined by test or a review of circuit parameters. Interconnection and compatible models indicated on installation wiring diagram for detector (base) and/or control unit.

D1 - Listing limited to specific system control unit. Information on compatible control unit indicated on installation drawing of control unit and/or detector.

D2 - For connection to Listed control units with which compatibility was determined by test or a review of circuit parameters. Interconnection and compatible models indicated on installation wiring diagram for detector (base) and/or control unit.

OAP - Open Area Protection
 PB - Projected Beam
 P - Photoelectric
 I - Ionization
 IHD - Includes Integral Heat Detector

Smoke Detectors

Certificates Overview

UL ONLINE CERTIFICATIONS DIRECTORY

UQGS.S25420
Heat-automatic Fire Detectors

Page Bottom

Heat-automatic Fire Detectors

See General Information for Heat-automatic Fire Detectors

SHIELD FIRE SAFETY & SECURITY LTD 525420
REDBURN HOUSE
2A TONBRIDGE ROAD
ROMFORD, ESSEX RM3 8QE UNITED KINGDOM

Model No.	Type	Compatibility Restrictions	Contact Arrangement	Temp Range (°F)	Spacing (Ft)	
					Smooth Ceiling	to Wall or Partition
S-A4013	FT/ROR	D2	-	131-194	60	25
S-C2013	FT/ROR	D2	-	135	50	25
S-C2014	FT/ROR	D2	-	170	50	25
S-C2015	FT/ROR	D2	-	200	50	25

D2 - For connection to Listed control units with which compatibility was determined by test or a review of circuit parameters. Interconnection and compatible models indicated on installation wiring diagram for detector (base) and/or control unit.
FT/ROR - Fixed temperature/rate of rise combination

Trademark and/or Tradename: SHIELD SHIELD

Last Updated on 2016-05-04

Questions? [Print this page](#) [Terms of Use](#) [Page Top](#)

© 2016 UL LLC

The appearance of a company's name or product in this database does not in itself assure that products so identified have been manufactured under UL's Follow-Up Service. Only those products bearing the UL Mark should be considered to be Certified and covered under UL's Follow-Up Service. Always look for the Mark on the product.

UL permits the reproduction of the material contained in the Online Certification Directory subject to the following conditions: 1. The Guide Information, Assemblies, Constructions, Designs, Systems, and/or Certifications (files) must be presented in their entirety and in a non-misleading manner, without any manipulation of the data (or drawings); 2. The statement "Reprinted from the Online Certifications Directory with permission from UL" must appear adjacent to the extracted material. In addition, the reprinted material must include a copyright notice in the following format: "© 2016 UL LLC".

Heat Detectors

UL ONLINE CERTIFICATIONS DIRECTORY

ULSZ.S24889
Audible-signal Appliances

Page Bottom

Audible-signal Appliances

See General Information for Audible-signal Appliances

SHIELD FIRE SAFETY & SECURITY LTD 524889
REDBURN HOUSE
2A TONBRIDGE ROAD
ROMFORD, ESSEX RM3 8QE UNITED KINGDOM

Device	Model	Installation Location	Enclosure Ratings	
			Type Rating Per UL 50	IEC "IP" Rating
Bell	FB1000C5	Indoor/Outdoor	-	-
Bell	FB1000C8	Indoor/Outdoor	-	-
Sounder	S-A4021	Indoor/Outdoor	None	None
Sounder	S-A4022	Indoor/Outdoor	None	None
Sounder Beacon	S-A4025	Indoor/Outdoor	None	None

Last Updated on 2013-12-09

Questions? [Print this page](#) [Terms of Use](#) [Page Top](#)

© 2016 UL LLC

The appearance of a company's name or product in this database does not in itself assure that products so identified have been manufactured under UL's Follow-Up Service. Only those products bearing the UL Mark should be considered to be Certified and covered under UL's Follow-Up Service. Always look for the Mark on the product.

UL permits the reproduction of the material contained in the Online Certification Directory subject to the following conditions: 1. The Guide Information, Assemblies, Constructions, Designs, Systems, and/or Certifications (files) must be presented in their entirety and in a non-misleading manner, without any manipulation of the data (or drawings); 2. The statement "Reprinted from the Online Certifications Directory with permission from UL" must appear adjacent to the extracted material. In addition, the reprinted material must include a copyright notice in the following format: "© 2016 UL LLC".

Sounder Beacons

UL ONLINE CERTIFICATIONS DIRECTORY

UTHA.S35725
Commercial/Residential Single- and Multiple-station Smoke Alarms

Page Bottom

Commercial/Residential Single- and Multiple-station Smoke Alarms

See General Information for Commercial/Residential Single- and Multiple-station Smoke Alarms

SHIELD FIRE SAFETY & SECURITY LTD 535725
REDBURN HOUSE
2A TONBRIDGE ROAD
ROMFORD, ESSEX RM3 8QE UNITED KINGDOM

Model No.	Type	Principle	Supply Connection	Date of Manufacture	Time of Manufacture Firmware Version	Firmware Version Update
S-B1026, S-B1026-H, S-B1026-IH, S-B1026-R, S-B1026-HR, S-B1026-IHR	SS, MS	Photo	220 Vac	-	-	-

SS - Single station
MS - Multiple station

Date of Manufacture identifies the manufacturing start date of all product models that will use the specific Time of Manufacture Firmware Version. The date of manufacture is recorded and in the format YEAR (in 4 digits), MONTH (in letters), DAY (in 2 digits).

Time of Manufacture Firmware Version identifies a numerical and/or alphabetic series designation that is product and date-code specific and will only identify the Firmware Version at the time the product was manufactured. The numeric and/or alphabetic sequence is defined by the manufacturer.

Firmware Version Update is a numerical and/or alphabetic sequential identification that is product and date-code specific and sequentially identifies the Firmware Version Update from the previous version of firmware. The numerical and/or alphabetic sequence is defined by the manufacturer.

Trademark and/or Tradename: SHIELD SHIELD

Last Updated on 2016-05-04

Questions? [Print this page](#) [Terms of Use](#) [Page Top](#)

© 2016 UL LLC

The appearance of a company's name or product in this database does not in itself assure that products so identified have been manufactured under UL's Follow-Up Service. Only those products bearing the UL Mark should be considered to be Certified and covered under UL's Follow-Up Service. Always look for the Mark on the product.

UL permits the reproduction of the material contained in the Online Certification Directory subject to the following conditions: 1. The Guide Information, Assemblies, Constructions, Designs, Systems, and/or Certifications (files) must be presented in their entirety and in a non-misleading manner, without any manipulation of the data (or drawings); 2. The statement "Reprinted from the Online Certifications Directory with permission from UL" must appear adjacent to the extracted material. In addition, the reprinted material must include a copyright notice in the following format: "© 2016 UL LLC".

Interconnected Detectors

ULC ONLINE DIRECTORIES

UUMWC.S35743
Speakers and Accessories for Fire Alarm Systems

Page Bottom

Speakers and Accessories for Fire Alarm Systems

See General Information for Speakers and Accessories for Fire Alarm Systems

SHIELD FIRE SAFETY & SECURITY LTD 535743
REDBURN HOUSE
2A TONBRIDGE ROAD
ROMFORD, ESSEX RM3 8QE UNITED KINGDOM

Speakers:

Model	Input Voltage, V	Power Taps, W	Comments
SSPK-C2000	70 Vrms	2	4" round, for indoor use only.
SSPK-W2000	70 Vrms	1, 2	4" square, for indoor use only.

Accessories:

Model	Type	Comments
SSPK-C2050	Backbox	4" round, flush mount; for use with SSPK-C2000 speakers
SSPK-W2050	Backbox	4" square, flush mount; for use with SSPK-W2000 speakers

Last Updated on 2016-04-11

Questions? [Print this page](#) [Terms of Use](#) [Page Top](#)

Copyright © 2016 Underwriters Laboratories of Canada Inc.

When the UL Leaf Mark is on the product, or when the word "Environment" is included in the UL Mark, please search the [UL Environment database](#) for additional information regarding this product's certification.

The appearance of a company's name or product in this database does not in itself assure that products so identified have been manufactured under UL's Follow-Up Service. Only those products bearing the UL Mark should be considered to be Listed and covered under UL's Follow-Up Service. Always look for the Mark on the product.

ULC permits the reproduction of the material contained in the ULC Online Directories subject to the following conditions: 1. The Guide Information, Designs and/or Listings (files) must be presented in their entirety and in a non-misleading manner, without any manipulation of the data (or drawings); 2. The statement "Reprinted from the ULC Online Directories with permission from Underwriters Laboratories of Canada Inc." must appear adjacent to the extracted material. In addition, the reprinted material must include a copyright notice in the following format: "Copyright © 2016 Underwriters Laboratories of Canada Inc."

An independent organization working for a better world with integrity, passion and innovation

Speakers

SHIELD[®]

TRUSTED WORLDWIDE

ADDRESSABLE FIRE DETECTORS & STANDARD BASES

The SHIELD range of Addressable Fire Detectors is advanced in design and performance and offers unique features that benefit both the installer and the end user.

SHIELD Fire Detectors uses a 'central intelligence' system where all the decisions are made by the control panel. Each detector is addressed using SHIELD's patented XPERT Card and supplied with the mounting bases. The SHIELD product line includes a photo-electric detector, a heat detector, a multisensor, an isolator and a series of modules.

KEY FEATURES:

- XPERT Card addressing
- Analog value report
- Alarm flags for fast alarm response
- Synchronization of all loop powered notification devices
- Advanced error check

SIGNALING



S-A4011

Photo-Electric Smoke Detector



SHIELD Photo-Electric Smoke Detector works on the light-scatter principle and is ideal for applications where slow-burning or smoldering fires are likely.

- Responds well to slow-burning, smoldering fires.
- Well suited for bedrooms and escape routes.
- Unaffected by atmospheric pressure.

Technical Data	
Detector Type	Photoelectric
Working Voltage	17 - 28 V DC
Modulation Voltage (V peak to peak)	5 - 9 V
Maximum Alarm Current LED On	4 mA
Surge Current	1 mA
Supervisory Current	340 μ A Avg, 600 μ A Peak
Storage Temperature Range	-22°F to 176°F
Operating Temperature Range	32°F to 100°F
Coverage	900 sq. ft.
Dimensions (diameter x height)	100 mm x 42 mm
Weight	105 g

S-A4013

Heat Detector



SHIELD Heat Detector is distinguishable by the low airflow resistant case and uses a single thermistor to sense the air temperature around the detector.

- Ideal for environments that are dirty or smoky under normal conditions.
- Well suited for warehouses, loading docks and parking garages.
- Unaffected by wind or atmospheric pressure.
- Remote test feature.

Technical Data	
Detector Type	Heat
Working Voltage	17 - 28 V DC
Modulation Voltage (V peak to peak)	5 - 9 V
Maximum Alarm Current LED On	3 mA
Surge Current	1 mA
Supervisory Current	250 μ A Avg, 500 μ A Peak
Heat Element Rating	135°F (57°C)
Test Method	Hair Dryer
Alarm Range	55°C to 90°C
Operating Temperature Range	131°F to 194°F
Coverage	600 sq. ft.
Dimensions (diameter x height)	100 mm x 42 mm
Weight	105 g

Note: Specifications are subject to change without notice

S-A4014



Multisensor

SHIELD Multisensor contains a photo-electric smoke sensor and a thermistor (temperature sensor) whose outputs are combined to give the final analog value.

- Sensitive to a wide range of fires.
- Well suited for environments such as hotel bedrooms, warehouses & loading docks.
- Unaffected by wind or atmospheric pressure.

Technical Data

Detector Type	Photoelectric Smoke Sensor and Thermistor
Working Voltage	17 - 28 V DC
Modulation Voltage (V peak to peak)	5 - 9 V
Maximum Alarm Current LED On	3 mA
Surge Current	1 mA
Supervisory Current	500 µA Avg, 750 µA Peak
Operating Temperature Range	32°F to 140°F
Coverage	900 sq. ft.
Dimensions (diameter x height)	100 mm x 50 mm
Weight	105 g

S-A4001 / S-A4003



Mounting Base

SHIELD Mounting Base which is a low insertion force base with stainless steel contacts for the detector terminals. XPERT Cards are supplied with all bases.

- XPERT addressing.
- One way fit.
- Locking feature to prevent unauthorized removal.

Ordering Information

S-A4001	Standard Mounting Base 4"
S-A4003	Standard Mounting Base 6"

Note: Specifications are subject to change without notice

S-A4006



E-Z Fit Base

The E-Z Fit Base is a low profile 6" mounting base for SHIELD detectors.

- High degree of protection against unauthorized removal.

Note: Specifications are subject to change without notice



SHIELD[®]

TRUSTED WORLDWIDE

SPECIAL ADDRESSABLE BASES

- Low Power Relay Base
- Isolating Base

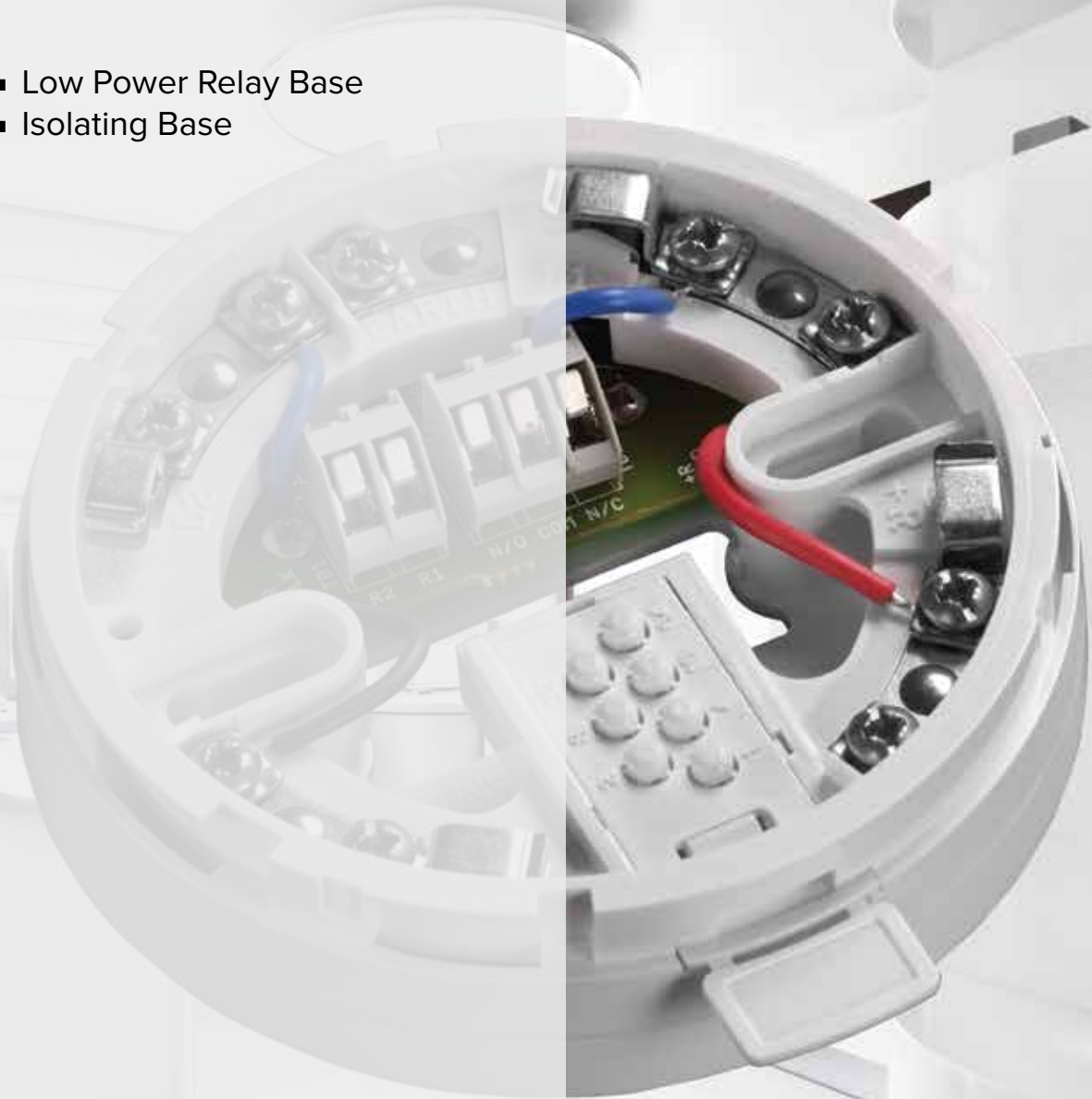

SIGNALING



LISTED



LISTED



S-A4005

Low Power Relay Base



SHIELD Low Power Relay Base incorporates a low power relay to control field equipment such as automatic door closers.

- Gives a set of voltage free contacts controlled by the remote output of a detector.
- Draws negligible current.

Technical Data

Type	Low Power Relay Base
Style	Base
Working Voltage	17 – 28 V DC
Modulation Voltage (peak to peak)	5 – 9 V DC
Relay Set	40 μ A
Surge Current	5 mA
Supervisory Current	<1 μ A
Relay Contact Ratings (resistive)	1 A at 30 V DC
Operating Temperature	14°F to 140°F
Base Material	Polycarbonate, White, V-0 to UL94
Dimensions (diameter x height)	100 mm x 24 mm

*(UL approved continuous operating range)

S-A4007

Isolating Base



SHIELD Isolating Bases are designed to sense and isolate short-circuits on loop and can be used in place of standard detector bases.

- XPERT addressing.

Technical Data

Type	20D Isolating Base
Style	Base
Working Voltage	17 – 28 V DC
Modulation Voltage (peak to peak)	5 – 9 V DC
Surge Current	0 mA
Supervisory Current	35 μ A
Maximum Line Current	1 A
Operating Temperature	0°F to 155°F
Base Material	Polycarbonate, White, V-0 to UL94
Dimensions (diameter x height)	100 mm x 25 mm

*(UL approved continuous operating range)

Note: Specifications are subject to change without notice

SHIELD[®]

TRUSTED WORLDWIDE

CONVENTIONAL FIRE DETECTORS AND BASE

The SHIELD conventional detectors incorporate well-proven sensing technologies with advances in materials & electronics technology. A wide operating voltage of 9 to 33 V DC means that SHIELD detectors can be integrated into security systems when used with a relay base.

SIGNALING



LISTED



LISTED

S-C2011



Photo-Electric Smoke Detector

SHIELD Photo-Electric Smoke Detector incorporates a pulsing LED located within the housing of the detector. The detector housing is identical to that of the Ionization Detector but has an indicator LED which is clear in quiescent state but produces red light in alarm.

- Responds well to slow-burning, smoldering fires.
- Well suited for bedrooms and escape routes.
- Unaffected by wind or atmospheric pressure.
- Wide operating voltage.

Technical Data

Detector Type	Photoelectric
Working Voltage	9 – 33 V DC
Maximum Alarm Current	17 mA at 9 V, 60 mA at 28 V
Surge Current	115 µA
Supervisory Current	40–50 µA at 9 V, 45–55 µA at 24 V
Test Method	Magnet or Gemini 501
Installation Temperature	32°F to 140°F
Dimensions (diameter x height)	100 mm x 50 mm
Weight	99 g

S-C2013



Heat Detector (135°F / 57°C)

SHIELD Heat Detector monitors temperature by using a dual thermistor network which provides a voltage output proportional to the external air temperature. There are nine heat detectors in the series range designed to suit a wide variety of operating conditions.

- Can be used for applications where smoke detectors are unsuitable.
- Ideal for environments that are dirty or smoky under normal conditions.
- Wide operating voltage.

Technical Data

Detector Type	Heat Rate-of-Rise / Fixed Temperature
Working Voltage	9 – 33 V DC
Maximum Alarm Current	60 mA
Surge Current	0 mA
Supervisory Current	40–50 µA at 9 V, 45–55 µA at 24 V
Heating Element Rating	Ordinary (135°F/57°C)
Test Method	Magnet or Hair Dryer
Installation Temperature	Minimum 32°F (0°C), Maximum At Least 20°F (11°C) Below Rating
Dimensions (diameter x height)	100 mm x 50 mm
Weight	80 g

Note: Specifications are subject to change without notice

S-C2014

Heat Detector (170°F / 77°C)



SHIELD Heat Detector monitors temperature by using a dual thermistor network which provides a voltage output proportional to the external air temperature. There are nine heat detectors in the series range designed to suit a wide variety of operating conditions.

- Can be used for applications where smoke detectors are unsuitable.
- Ideal for environments that are dirty or smoky under normal conditions.
- Wide operating voltage.

Technical Data

Detector Type	Heat Rate-of-Rise / Fixed Temperature
Working Voltage	9 – 33 V DC
Maximum Alarm Current	17 mA at 9 V, 52 mA at 24 V
Surge Current	0 mA
Supervisory Current	40–50 µA at 9 V, 45–55 µA at 24 V
Heating Element Rating	Ordinary (170°F/77°C)
Test Method	Magnet or Hair Dryer
Installation Temperature	Minimum 32°F (0°C), Maximum At Least 20°F (11°C) Below Rating
Dimensions (diameter x height)	100 mm x 50 mm
Weight	80 g

S-C2015

Heat Detector (200°F / 93°C)



SHIELD Heat Detector monitors temperature by using a dual thermistor network which provides a voltage output proportional to the external air temperature. There are nine heat detectors in the series range designed to suit a wide variety of operating conditions.

- Can be used for applications where smoke detectors are unsuitable.
- Ideal for environments that are dirty or smoky under normal conditions.
- Wide operating voltage.

Technical Data

Detector Type	Heat Rate-of-Rise / Fixed Temperature
Working Voltage	9 – 33 V DC
Maximum Alarm Current	17 mA at 9 V, 52 mA at 24 V
Surge Current	0 mA
Supervisory Current	40–50 µA at 9 V, 45–55 µA at 24 V
Heating Element Rating	Intermediate (200°F/93°C)
Test Method	Magnet or Hair Dryer
Installation Temperature	Minimum 32°F (0°C), Maximum At Least 20°F (11°C) Below Rating
Dimensions (diameter x height)	100 mm x 50 mm
Weight	80 g

Note: Specifications are subject to change without notice

S-C2001

Standard Mounting Base



SHIELD conventional standard base has been designed to enable detectors to be fitted without the need of force - particularly useful when fitting to suspended ceilings. All bases have one way only fit.

- 2 wire base.
- One way fit.
- Easy to wire.
- Detector locking mechanism.
- Contains no electrical parts.



Note: Specifications are subject to change without notice



SHIELD[®]

TRUSTED WORLDWIDE

INTERCONNECTED DETECTORS
(9V DC & 230V AC)

- Heat Detector
- Smoke Detector
- Multi Detector



SIGNALING



LISTED

S-B1036

Interconnected Heat Detector



Description

The Interconnected Heat Detector is for use as a warning device in residential applications. Each detector has a solid state piezo signal to warn and alert the household to the presence of threatening heat.

The Interconnected heat detector is designed to detect heat that results from an actual fire. Heat detectors are intended for use as supplements to smoke detectors. This unit cannot detect smoke or toxic gases, therefore, do not rely solely on this heat detector to provide a warning of fire.

In the event AC power fails, a 9VDC battery will provide proper detector operation for a minimum of a 24-hour period.

Standard Features

- Available in 220VAC with 9VDC battery back-up.
- Horn frequency 3100Hz (nominal).
- 135°F fixed temperature.
- 90dBA temporal 3 piezo horn.
- Solid-state LED condition indicator.
- Quick-disconnect wiring harness.
- Tandem interconnect with current Shield detectors.
- Mounting hardware adapts to standard junction boxes.
- Low or missing battery indicator.

Tandem Wiring Diagram

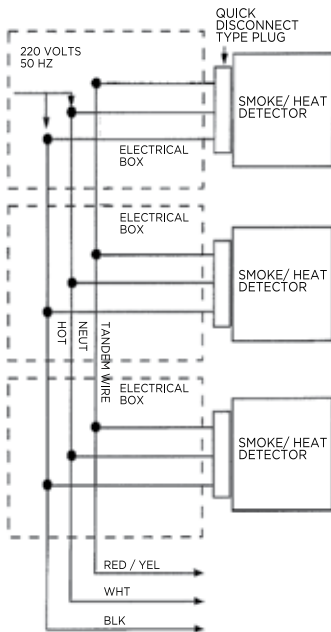

CAUTION:
All detectors in a tandem installation must be controlled by the same fuse or circuit breaker. Otherwise tandem units will not operate. Tandem will operate in the event of an AC power failure if battery is connected to the detector.

LIMITATIONS:
A heat detector can be connected to a maximum of 12 smoke and 5 other heat detectors, to total not more than 18 interconnected devices. Do not exceed 1125 feet between the first and last detector.

NOTE:
Wire used for interconnecting shall be in accordance with Article 300.3 (b) and Article 210 of the National Electrical Code (NEC) and NFPA 70.

Technical Data

Operating Voltage	230V AC, 50Hz
Operating Current	0.035 A
Operating Ambient Temp Range	0°F to 110°F (-18°C to 43°C)
Alarm Horn Rating	90dBA at 10 Feet
Dimension	Diameter at Base: 5.75 in. (14.605 cm) Overall Diameter: 6.5 in. (16.51 cm) Depth: 2.625 in. (6.6675 cm)
Secondary Power Source	Alkaline 9V DC Battery Duracell MN 1604

Ordering Information

Model Number	Voltage	Temporal 3 Piezo Sounder
S-B1036	220V AC	●

Heat Detector Wiring Diagram

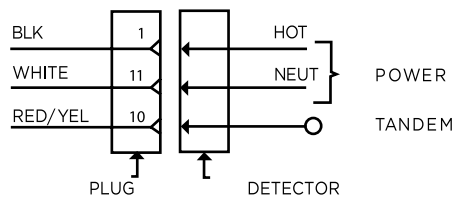

CAUTION
RED/YELLOW WIRE:
DO NOT REMOVE
INSULATION CAP
UNLESS CONNECTING
ANOTHER DETECTOR

S-B1026

Interconnected Battery Operated Smoke / Multi Detector



Description

The Interconnected Photoelectric Smoke / Multi Detector is designed for residential and commercial residential applications, including homes, apartments, hospitals, hotels and motels, in compliance with UL217, UL1730 applicable IBC/IFC Standards and NFPA72.

Available in many different models, the detector is engineered to virtually eliminate nuisance alarms and deliver outstanding performance wherever reliable fire protection is required. The range is provided with a 9VDC alkaline battery for back-up in the event building power is lost. The battery impedance is verified and the alarm provides a low or missing battery warning.

This range of detector provides an exclusive patented three position test feature that simulates a 0.85% and 3.5% actual smoke condition in full compliance with NFPA72 and UL Standards.

Options include self-restoring 135°F integral or isolated heat thermals and Form A/Form C dry contacts for remote annunciation. Tandem interconnection of up to 12 units is available on several models; tandem interconnection of up to 6 units is available on “R” models, which activate the dry contacts from the tandem wire or a local alarm.

Standard Features

- Available in 220VAC with 9VDC battery back-up.
- Horn frequency 3100 Hz (nominal).
- Nominal 2.5% sensitivity.
- Patented three position test switch.
- Relays operate on battery back-up.
- Quick-disconnect wiring harness.
- 90dBA temporal 3 evacuation piezo horn.
- 5-to-1 signal-to-noise ratio.
- Pulsing LED sensing chamber.
- Fully insect screened.
- Interconnect with all tandem capable smoke alarms.
- Red LED pulses every 30 seconds, green LED for AC power on.
- Mounting hardware adapts to standard junction boxes.
- Dust cover to prevent contamination during installation.
- Low or missing battery indicator.

Technical Data	
Operating Voltage	230V AC, 50Hz
Operating Current	0.035 A
Operating Ambient Temp Range	0°F to 110°F (-18°C to 43°C)
Alarm Horn Rating	90dBA at 10 Feet
Dimension	Diameter at Base: 5.75 in. (14.605 cm)
	Overall Diameter: 6.5 in. (16.51 cm)
	Depth: 2.625 in. (6.6675 cm)
Secondary Power Source	Alkaline 9V DC Battery Duracell MN 1604

Note: Specifications are subject to change without notice



Ordering Information

Model Number	Voltage	Integral 135°F Thermal	Isolated 135°F Thermal	Tandem Up To 12 Units	Tandem Up To 6 Units	Form A/C Contacts
S-B1026	220V AC			●		
S-B1026-H	220V AC	●		●		
S-B1026-IH	220V AC		●	●		
S-B1026-R	220V AC				●	●
S-B1026-HR	220V AC	●			●	●
S-B1026-IHR	220V AC		●		●	●

Notes:

- Series available in round configuration only.
- It is recommended that smoke detector be tested weekly.
- Units produce a temporal 3 audible detector. Per NFPA72, the American National Standard defined in ANSI S3.41, is Whenever the intended response is to evacuate the building.

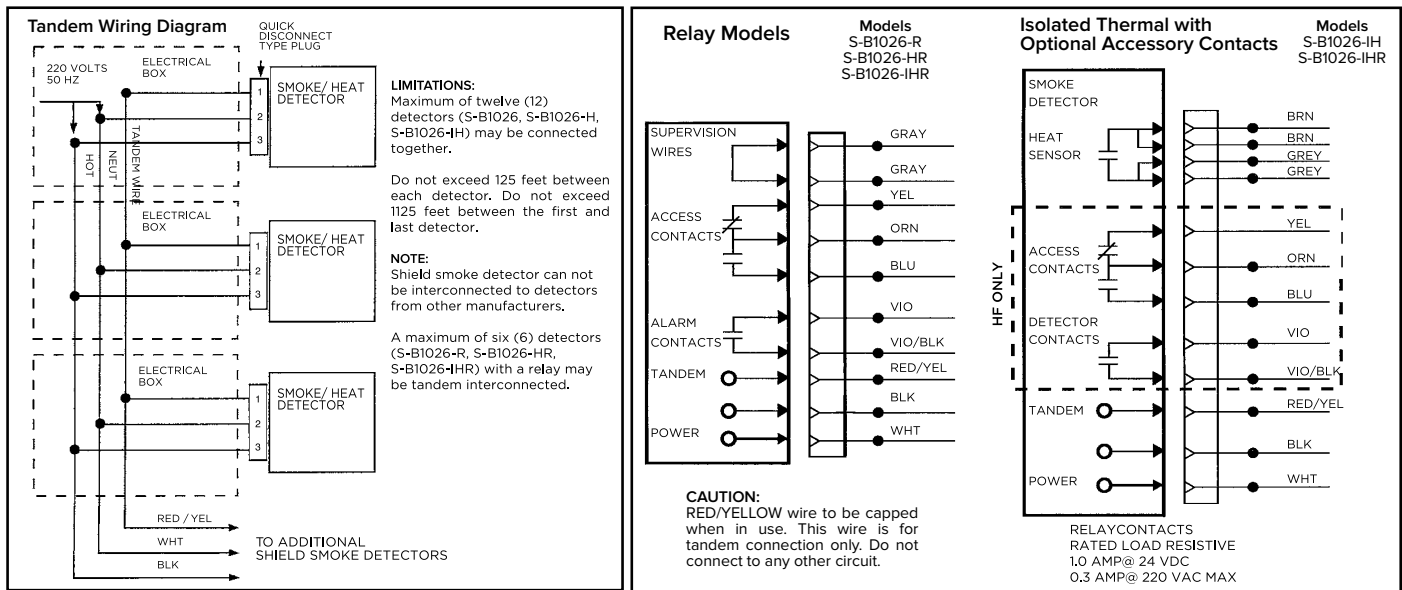

Note: Specifications are subject to change without notice

SHIELD[®]

TRUSTED WORLDWIDE

BEAM DETECTOR

- ALPHA 1000
- ALPHA 3000
- ALPHA 5000



SIGNALING



LISTED



LISTED

S-C1050 / S-C1100



Alpha 1000 Reflective Beam Detector

Description

The system comprises of a single unit incorporating an infrared transmitter and receiver. The signal generated in the transmitter element and reflected by the prism back to the receiver element is analyzed for the presence of smoke. The internal microprocessor determines an alarm condition when a predetermined level is reached.

The system is designed to be mounted so the beam will project between 0.5 m and 0.6 m below and parallel to the ceiling. Lateral detection may be up to 9.144m on either side of the beam, providing a maximum total coverage area of up to 19,800 square feet (18.29 m x 100 m).

Standard Features

- Easy set up and alignment.
- Single compact housing.
- Calibrated obscuration test filter included.
- Microprocessor controlled.
- Alarm latching or auto reset.
- Automatic gain control.
- 12 V DC or 24 V DC operation.
- Separate alarm and trouble contacts.
- Remote Test Station available.

Technical Data

Primary Input Power	10.2 to 30 V DC
Standby Current	4 mA @ 24 V DC
Alarm Current	15 mA @ 24 V DC
Relay Contacts	1A at 30 V DC Resistive
Reset Time	5 Seconds Maximum
Start Up Time	10 Seconds
Optical Wavelength	880 nm
Relative Humidity	10% to 93% RH Non-condensing
Housing	Flame Retardant ABS
IP Rating	IP50
Finish	Grey/Black
Range	S-C1050 (5 m to 50 m) S-C1100 (50 m to 100 m)
Temperature Rating	-20°C to +55°C
Sensitivity	25%, 35%, 50%
Dimensions (L x W x D)	210 mm x 126 mm x 120 mm
Weight	0.67 Kg

*(UL approved continuous operating range)

Ordering Information

S-C1050	Reflective Beam Smoke Detector 50 m
S-C1100	Reflective Beam Smoke Detector 100 m
S-C1002	Surface Mount Back Box
S-C1003	Surface Mount Wall Bracket

Note: Specifications are subject to change without notice

S-C3001

Alpha 3000 End to End Beam Detector



Description

The SHIELD Alpha 3000 End to End infrared Optical Beam Smoke Detector (OBSD) has been designed using the latest optical technology, incorporating modern industrial, electronic and software techniques. This detector offers cost effective protection of large, open area spaces with high ceilings. It is also very suited to applications where access to ceiling mounted smoke detectors presents practical difficulties.

The SHIELD Alpha 3000 is ideal for applications where line of sight for the IR (infrared) detection path is narrow and where the building structure uses reflective surfaces. It has also been designed to be aesthetically pleasing and thus can equally suit modern architectural buildings as well as historical sites, particularly where ornate ceilings exist.

Standard Features

- Separate Transmitter and Receiver Heads.
- Range 5 m to 120 m, configurable per set of Detectors.
- Lateral Spacing per NFPA 72 is 18 m.
- Integral Laser Alignment in Receiver.
- 2-wire Interface between Controller and Receiver.
- Single and Twin Channel capability.
- Separate Fire and Fault Relays per Detector.
- Low Level Controller with LCD display.
- Programmable Sensitivity and Fire Threshold.
- Automatic Gain Control (AGC) for drift compensation.
- Built-in electronic UL/ULC obscuration-acceptance fire test.
- Knockouts for ease of installation and wiring .
- Optional Transmitter powering from Controller.

Technical Data

Operating Range	5 - 120 m
Operating Voltage Range	12 to 36 V DC
Operating Controller Current (with 1 or 2 receivers)	14 mA (constant)
Operating Transmitter Current	8 mA (per transmitter)
Power Down Reset Time	>20 Seconds
Fire and Fault Relay Contacts	Resistive VFCO 2A @ 30 V DC
Operating Temp. (non-condensing)	-20°C to +55°C
Optical Wavelength	850 nm
IP Rating	IP54
Relative Humidity (non-condensing)	93%
Dimension (W x H x L) & Weight	
Control Unit	203 mm x 124 mm x 71 mm, 600 g
Transmitter & Receiver	78 mm x 77 mm x 161 mm, 200 g

Ordering Information

S-C3001	End To End Beam Detector Includes 1 x Transmitter, 1 x Receiver & 1 x Sytem Control Unit
S-C3002	Additional Detector Pack (set of transmitter and receiver heads)
S-C3003	Alpha 3000 Adjustment Bracket
S-C3004	Alpha 3000 Surface Mount Adaptor

Note: Specifications are subject to change without notice

S-C5001



Alpha 5000 Auto Align Beam Detector

Description

The Alpha 5000 System is an auto-aligning, self-correcting infrared beam smoke detector. Upto 2 detector heads can report to a single ground level controller. In addition, each system controller houses two pairs of fire and trouble relays, one per detector. Once the detector head is installed, using the easyfit mounting system an integral LASER can be activated. This allows the reflective prism to be located quickly and with confidence.

Auto-Align function ensures proper alignment and maximum signal during the beam installation. Auto Optimise automatically steers and maintains the beam in the optimum position for reliable performance. The signal generated in the transmitter element and reflected by the prism back to the receiver element is analyzed for the presence of smoke. The internal microprocessor determines an alarm condition when a predetermined level obscuration is reached.

Standard Features

- Upto 2 Detector Heads reporting to One Ground Level Controller.
- Built in Laser assisted prism mounting.
- Auto-Alignment 2 to 4 minutes per head.
- Auto Optimise: Auto-Correction due to building shift.
- Built-in electronic UL/ULC obscuration-acceptance fire test.
- Contamination compensation.
- Separate Trouble and Alarm relays for each of the 2 channels.
- Password protected settings.
- Programmable alarm thresholds: 10% - 60% in 1% increments.
- Programmable Fault and Alarm delay: 2-30 Seconds.

Technical Data

Primary Input Power	14 to 36 V DC
Standby Current (depending on number of detector heads)	Low Current : 5 mA to 8.5 mA @ 24 V DC High Current : 37 mA @ 24 V DC
Alarm Current	5 mA to 8.5 mA @ 24 V DC Depending On Number Of Detector Heads Used
Relay Contacts	1 A @ 30 V DC Resistive
Reset Time	5 Seconds Maximum
Start Up Time	45 Seconds
Optical Wavelength	850 nm
Temperature Rating UL Listed	-10°C to +55°C
IP Rating	IP54
Dimension (W x H x L) & Weight	
Head	134 mm x 134 mm x 131 mm, 1470 g
Controller	202 mm x 87 mm x 230 mm, 1470 g
Prism	100 mm x 9.5 mm x 105 mm

Ordering Information

S-C5001	Reflective Auto Align Beam Smoke Detector 8 m to 100 m (1 detector head, 1 controller and 1 prism)
S-C5002	Auto-aligning Optical Beam Smoke Detector 8-50 Range (1x TX/RX head, 1x system control unit & 1 prism)
S-C5003	Additional Detector Head TX/RX 100 m With 4 Prism
S-C5004	Additional Detector Head TX/RX 50 m With 1 Prism

Note: Specifications are subject to change without notice

SHIELD[®]

TRUSTED WORLDWIDE

ADDRESSABLE MODULES

(Loop Powered)



SIGNALING



LISTED



LISTED

S-A4041

Mini Monitor Module



The Mini Monitor Module is an interface within an entirely new housing. This allows the unit to be fitted onto a standard 35mm DIN-Rail (using a twistclick motion) or mounted within an enclosure, such as a Pull Station. It is designed to monitor the state of one or more single pole, voltage free contacts connected on a single pair of cables and to report the status to compatible analog control equipment.

- DIN-Rail mountable.
- Designed for use where space is limited.
- Interrupt/non-interrupt in one unit.
- 'Pre-alarm' status available.
- Three, colored LEDs, giving clear status indication.

Technical Data

Operating Voltage	17-28 V DC
Modulation Voltage	5-9 V (peak to peak)
Designed To	24 V DC Nominal
Current Consumption at 24V	
Quiescent Current	200 µA
LED Operated Alarm	3.4 mA + Quiescent
Remote And Led Alarm	6.2 mA + Quiescent
Switch Fault LED	+2.8 mA (pulsing 0.5 s on, 0.5 s off)

S-A4042

Dual Priority Switch Monitor Module



SHIELD Dual Priority Switch Monitor Module contains two Priority Switch Monitor Modules on a single plate.

- Loop-powered.
- Fast response time.
- Interrupt facility.

Technical Data

Style	Fascia Plate With Wiring Terminals	
Temperature Range	32°F to 120°F	
Wiring Size	24 AWG - 14 AWG	
Signal Line Circuit (SLC)	Supervised Power Limited	
Working Voltage	17 - 28 V DC	
Modulation Voltage	5 - 9 V DC (peak to peak)	
Operating Current	Supervisory Current	1.5 mA
	Surge Current	2.5 mA
	Maximum Alarm Current	5 mA
Functional States	Analog Level (normal)	16
	Analog Level (alarm)	64
	Analog Level (trouble)	4
Dimensions (L x W x D)	114 mm x 114 mm x 25 mm	

Note: Specifications are subject to change without notice

S-A4043

Switch Monitor Module



SHIELD Switch Monitor Module is designed to monitor the state of one or more single pole, voltage free contacts connected and to report the status to SHIELD compatible analog control equipment.

- Three input states - 'normal', 'trouble', and 'alarm'.
- Visible LED.
- Loop-powered.

Technical Data		
Style	Fascia Plate With Wiring Terminals	
Temperature Range	32°F to 120°F	
Wiring Size	24 AWG - 14 AWG	
Signal Line Circuit (SLC)	Supervised Power Limited	
Working Voltage	17 - 28 V DC	
Modulation Voltage	5 - 9 V DC (peak to peak)	
Operating Current	Supervisory Current	1.1 mA
	Surge Current	2.5 mA
	Maximum Alarm Current	5 mA (LED on)
Functional States	Analog Level (normal)	16
	Analog Level (alarm)	64
	Analog Level (trouble)	4
Dimensions (L x W x D)	114 mm x 114 mm x 25 mm	

S-A4045

Switch Monitor Input/Output Module



SHIELD Switch Monitor Input/Output Module provides a voltage free, single pole, change-over relay output, a single monitored switch input and unmonitored, non-polarized opto-coupled input.

- Reports 'trouble', 'switch open' and 'switch closed' levels.
- Visible LED.
- Loop-powered.

Technical Data		
Style	Fascia Plate With Wiring Terminals	
Temperature Range	32°F to 120°F	
Wiring Size	24 AWG - 14 AWG	
Signal Line Circuit (SLC)	Supervised Power Limited	
Working Voltage	17 - 28 V DC	
Modulation Voltage	5 - 9 V DC (peak to peak)	
Operating Current	Supervisory Current	850 µA
	Surge Current	7.5 mA
	Maximum Alarm Current	6.0 mA (LED on)
Functional States	Analog Level (normal)	16
	Analog Level (alarm)	64
	Analog Level (trouble)	4
Dimensions (L x W x D)	114 mm x 114 mm x 25 mm	

Note: Specifications are subject to change without notice

S-A4046

Sounder Control Module



SHIELD Sounder Control Module monitors and controls the operation of a zone of conventional sounders and reports their status to the control panel.

- Allows sounders to be operated continuously or be pulsed, 1 second on, 1 second off.
- May be synchronized when in pulsed operation.
- Can also be used for public address speakers.

Technical Data		
Style	Fascia Plate With Wiring Terminals	
Temperature Range	32°F to 120°F	
Wiring Size	24 AWG - 14 AWG	
Signal Line Circuit (SLC)	Supervised Power Limited	
Working Voltage	17 - 28 V DC	
Modulation Voltage	5 - 9 V DC (peak to peak)	
Operating Current	Supervisory Current	1 mA
	Surge Current	2.5 mA
	Maximum Alarm Current	4 mA (LED on)
Functional States	Analog Level (normal)	16
	Analog Level (trouble)	4
Dimensions (L x W x D)	114 mm x 114 mm x 25 mm	

S-A4051

Isolator Module



The Isolator is placed at intervals on the loop and ensures that, in the case of a short circuit, only the section between the isolators will be affected. When the short circuit is removed, the isolators automatically restore power and data to the isolated section.

- Detects wiring short-circuits using patented technology.
- Minimizes disruption from short-circuits.
- Automatic de-isolation on short-circuit removal.
- Up to 20 devices may be installed between isolators.

Technical Data		
Device Type	Isolator	
Style	Mounting Base And Twist-In Isolator Module	
Working Voltage	17 - 28 V DC	
Operating Current	Modulation Voltage	5 - 9 V (peak to peak)
	Supervisory Current	2.5 mA
	Surge Current	0m A
	Maximum Current Drawn	8.5 mA
	Maximum Line Impedance	50 Ω
Temperature Range	32°F to 100°F	
Dimensions (diameter x height)	100 mm x 31.25 mm	
Weight	82 g	

Ordering Information	
S-A4051	Isolator Module
S-A4002	Isolator Base

Note: Specifications are subject to change without notice

S-A4047



Mini Priority Switch Monitor Module

SHIELD Mini Priority Switch Monitor Module is designed to monitor the state of one or more single pole, voltage free contacts and to report the status to SHIELD compatible analog control equipment. It can also place a signal on the loop to provide early warning if a device such as a pull station is operated.

- Loop-powered and three input states - 'normal', 'trouble' & 'alarm'.
- Visible LED with remote LED connection option.
- Designed to fit into equipment with limited space.

Technical Data

Style	Fascia Plate With Wiring Terminals	
Temperature Range	32°F to 120°F	
Signal Line Circuit (SLC)	Supervised Power Limited	
Working Voltage	17 - 28 V DC	
Modulation Voltage	5 - 9 V DC (peak to peak)	
Operating Current	Supervisory Current	1 mA
	Surge Current	2.5 mA
	Maximum Alarm Current	5 mA
Functional States	Analog Level (normal)	16
	Analog Level (alarm)	64
	Analog Level (trouble)	4
Dimensions (L x W x D)	76 mm x 50 mm x 12.5 mm	

S-A4048



Mini Switch Monitor Module

SHIELD Mini Switch Monitor Module is designed to monitor the state of one or more single pole, voltage free contacts and to report the status to compatible analog control equipment.

- Loop-powered and three input states - 'normal', 'trouble', and 'alarm'.
- Visible LED with remote LED connection option.
- Designed to fit into equipment with limited space.

Technical Data

Style	Fascia Plate With Wiring Terminals	
Temperature Range	32°F to 120°F	
Signal Line Circuit (SLC)	Supervised Power Limited	
Working Voltage	17 - 28 V DC	
Modulation Voltage	5 - 9 V DC (peak to peak)	
Operating Current	Supervisory Current	1 mA
	Surge Current	2.5 mA
	Maximum Alarm Current	5 mA
Functional States	Analog Level (normal)	16
	Analog Level (alarm)	64
	Analog Level (trouble)	4
Dimensions (L x W x D)	76 mm x 50 mm x 12.5 mm	

Note: Specifications are subject to change without notice

S-A4049



120V AC Input/Output Module

SHIELD 120V AC Input/Output Module is a loop powered device which incorporates a monitored input circuit for connection to dry contacts, as well as a 4A rated dry contact relay output. It is mounted on a plastic fascia plate for use with a 4" square or 2 gang electrical back box.

- Loop-powered.
- Visible LEDs.
- 4A rated dry contact.

Technical Data

Style	Fascia Plate With Wiring Terminals	
Temperature Range	32°F to 120°F	
Wiring Size	24 AWG - 14 AWG	
Signal Line Circuit (SLC)	Supervised Power Limited	
Operating Voltage	17 - 28 V DC 20-28 V DC (UL listed)	
Modulation Voltage	5 - 9 V DC (peak to peak)	
Operating Current	Supervisory Current at 17 V	<0.95 mA
	Alarm Current at 17 V	<2.80 mA
	Supervisory Current at 28 V	<0.95 mA
	Alarm Current at 28 V	<3 mA (LED on)
	Maximum Alarm Current	<5 mA
Functional States	Analog Level (normal)	16
	Analog Level (alarm)	64
	Analog Level (trouble)	4
Dimensions (L x W x D)	114 mm x 114 mm x 25 mm	

S-A4050



Relay Output Module

SHIELD Relay Output Module provides a single 2-pole change over relay.

- Loop-powered.
- Can be placed anywhere on loop.

Technical Data

Style	Fascia Plate With Wiring Terminals	
Temperature Range	32°F to 120°F	
Wiring Size	24 AWG - 14 AWG	
Signal Line Circuit (SLC)	Supervised Power Limited	
Working Voltage	17 - 28 V DC	
Modulation Voltage	5 - 9 V DC (peak to peak)	
Operating Current	Supervisory Current	0.85 mA
	Surge Current	2.50 mA
	Maximum Alarm Current	3.50 mA (LED on)
Functional States	Analog Level (normal)	16
Relay Output	Non Supervised, Dry Contact 24 V DC, 2 A; 30 V DC, 0.5 A	
Dimensions (L x W x D)	114 mm x 114 mm x 25 mm	

Note: Specifications are subject to change without notice

SHIELD[®]

TRUSTED WORLDWIDE

ADDRESSABLE NOTIFICATION DEVICES



SIGNALING



LISTED

S-A4021/ S-A4022

Open-Area Sounder



SHIELD Open-Area Sounder has been designed for use in open areas and can be connected to the loop (SLC) of the shield system.

- Self-test trouble monitoring.
- Two volume setting 92 dB(A) and 100 dB(A).
- Synchronization of tones.
- Individual and group addressing.
- Available in red or white.
- Loop-powered.
- IP65 rated.

Technical Data

Operating Voltage	17 – 28 V DC	
Maximum Low Current at 24 V	Normal Standby	< 310 µA
	Operated	28V Highest Audibility 5.4 mA
	Operated Switch On Surge	< 6 mA for 1 Sec
IP Rating	65	

Ordering Information

S-A4021	Open-Area Sounder (RED)
S-A4022	Open-Area Sounder (WHITE)

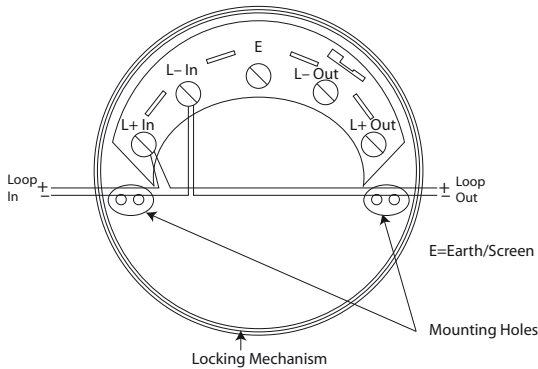

Fig 1. Base Diagram

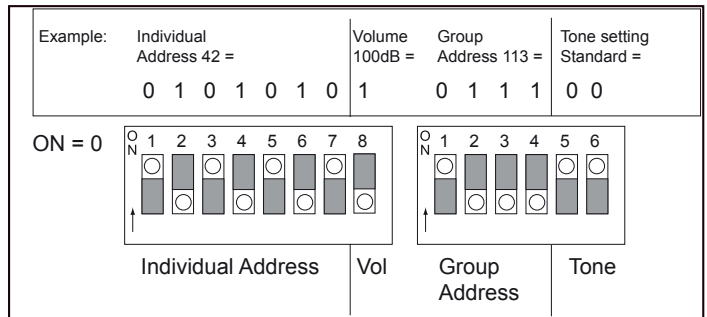

Fig 2. Address and Tone Setting

Low Volume (DIP 8 = ON)					
DIP 5	DIP 6	Output Bits	Tone Description	Tone	Output db(A) at 10ft
0	0	010	UL	Continuous 2900 Hz	70.6
0	0	100	UL	ANSI 2900 Hz	67.8
0	1	010	New Zealand	Pulsed 420 Hz	71.8
0	1	100	New Zealand	500-1200 Hz S/Whoop	70
1	0	010	Australian	Pulsed 420 Hz	71.6
1	0	100	Australian	500-1200 Hz S/Whoop	67.3
1	1	010	Standard	Pulsed	72.9
1	1	100	Standard	Continuous Alternating	75

Low Volume (DIP 8 = OFF)					
DIP 5	DIP 6	Output Bits	Tone Description	Tone	Output db(A) at 10ft
0	0	010	UL	Continuous 2900 Hz	79.1
0	0	100	UL	ANSI 2900 Hz	75.3
0	1	010	New Zealand	Pulsed 420 Hz	75.9
0	1	100	New Zealand	500-1200 Hz S/Whoop	75.5
1	0	010	Australian	Pulsed 420 Hz	75.2
1	0	100	Australian	500-1200 Hz S/Whoop	71.7
1	1	010	Standard	Pulsed	78.3
1	1	100	Standard	Continuous Alternating	80.8

Note: Specifications are subject to change without notice



S-A4025

Open-Area Sounder Beacon



SHIELD UL Open-Area Sounder Beacon makes full use of the protocol and has been designed for use in indoor, outdoor and open-areas. When the fire system is being commissioned, a Magnetic Wand can be used to adjust and test each sounder locally.

- 15 tone pairs.
- Sounder and beacon are independently configurable.
- Volume and tone settings are independently selectable from the control panel.
- Tones can be used for other purposes in addition to warning of fire, making the device ideal for use in schools etc.
- Soft start option, ideal for hospitals and nursing homes.
- Group and individual control for increased response time.

Technical Data

Operating Voltage	17 – 28 V DC	
Sounder Operating	Variable	
Maximum Low Current at 24 V	Normal Standby	< 750 μ A
	Operated	28 V Highest Audibility 5.4 mA
	Operated Switch On Surge	< 2.6 mA for 1 Sec
IP rating	65	

Ordering Information

S-A4025	Open-Area Sounder Visual Indicator (RED)
---------	--

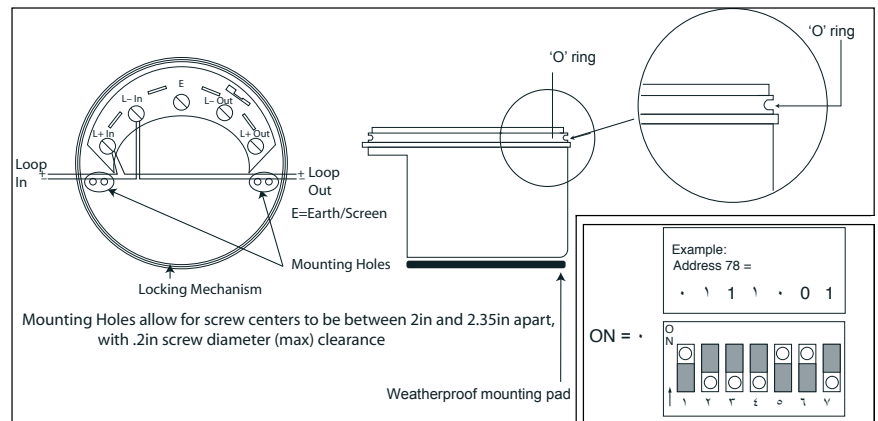

Fig 1. Wiring diagram

Fig 2. Example of Address

Note: Specifications are subject to change without notice

S-A4023 / S-A4024

Sounder Beacon Base

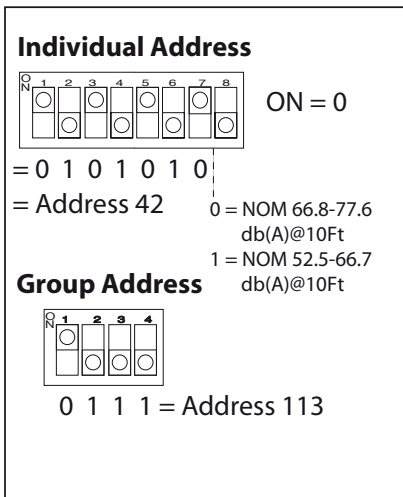

Fig 1. Address Example

SHIELD Sounder Beacon Base is a loop powered sounder and beacon combined with a standard Intelligent Mounting Base. It is used to signal a fire alarm in enclosed areas. The Sounder Beacon Base can be used either with a detector fitted or with a cap for operation as a stand-alone alarm device.

- Two volume ranges 55-75 dB(A) and 75-91 dB(A).
- Beacon flash rate of once per second.
- Synchronization of 'alert' and 'evacuate' tones.
- Synchronization of beacon flash.
- Individual and group addressing.
- Unique acoustic and beacon self test.

Technical Data

Operating Voltage	17 – 28 V DC	
Sounder Output	High Volume Setting	66.8 - 77.6 db (A) at 3.05 m
	Low Volume Setting	52.5 - 66.7 db (A) at 3.05 m
Current Consumption at 24 V DC	Normal Standby	< 900 µA
	Switch-On Surge	1.2 mA for 1 Sec
	Sounder/Beacon Operating	8.75 mA

Output Command Bits	2	1	0
(Evacuate Tone)	X	0	1
(Alert Tone)	X	1	0
(Evacuate Tone)	X	1	1

Ordering Information

S-A4023	Sounder Beacon Base (Yellow LED's)
S-A4024	Sounder Beacon Base (Red LED's)

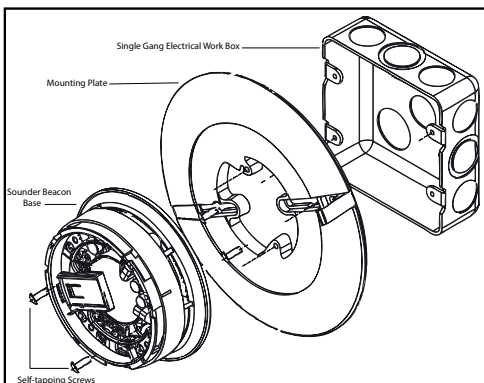

Fig 2 Adaptor Plate

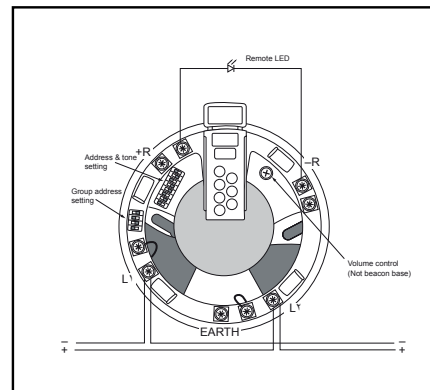

Fig 3. Base Wiring Diagram

Note: Specifications are subject to change without notice

SHIELD[®]

TRUSTED WORLDWIDE

ADDRESSABLE PULL STATIONS



SIGNALING



LISTED

S-A4061

Dual Action Pull Station



SHIELD Pull Station is dual action and features translucent plastic at the center, allowing visibility of an internal LED that indicates alarm condition and polling status. The unit is addressable using a DIP switch protected within the pull station. The Dual Action Pull Station may be flush mounted on a single gang work box or use an optional back cover.

- Control Panel Compatibility.
- Key lock.
- Easily resettable.
- LED visible even when Pull Station is closed.
- Redundancy to false alarm.

Technical Data

Operating Voltage	17 – 28 V DC	
	20 - 28 V DC (UL Listed)	
Current Consumption at 24 V	Normal Standby	200 µA
	Operated	3.6 mA + Quiescent
IP Rating	25	
Dimensions (W x H x D) mm	Pull Station	108 x 140x 28
	Back Box	108 x 140x 45
Weight	Pull Station	200 g
	Back Box	326 g

Ordering Information

S-A4061	Dual Action Pull Station - Addressable
S-A4062	Polycarbonate Backbox

Note: Specifications are subject to change without notice

SHIELD[®]

TRUSTED WORLDWIDE

ADDRESSABLE FIRE DETECTION
SYSTEMS



SIGNALING



LISTED



APPROVED

- OMEGA
- OMEGA-X
- OMEGA-R

SR-P10R /SR-P2LR

1 Loop / 2 Loops

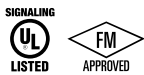

OMEGA Addressable Fire Alarm Control Panel

Product Overview

SHIELD Omega is a versatile range of open protocol fire alarm control panels compatible with existing SHIELD Omega fire alarm panel technology.

Available with one or two detection loops for a total of 250 primary points or 400 points using subpoints. SHIELD Omega uses leading edge microprocessor based electronics to provide a flexible control system with high reliability and integrity.

Suitable for all small to medium sized fire detection systems, SHIELD Omega control panels can be expanded and networked to become part of much larger systems if the need arises, therefore providing a future proof solution for any installation.

With its large graphical display and ergonomic button and indicator layout, the SHIELD Omega control panel is simple and straight forward to understand for installers, commissioning engineers and end users.

Standard Features

- One full SLC circuit expandable to two.
- 3 programmable relays.
- 5.25 A power supply.
- LCD Display: 8x40.
- Real time clock.
- Compatible with graphics annunciator.
- Up to 3048 m wiring length on SLC loop.
- 64 Panels on a network.
- Total of 250 primary points or 400 subpoints.
- Powerful, network wide cause and effects (500 total).
- Fully user programmable by point or zone.
- Can be networked with additional panel and / or SHIELD Omega panels.
- Compatible with Omega R Annunciator.
- Programmable through a PC connection to the panel.
- Same look and feel as SHIELD Omega range.
- Stores 1000 last events in history log.
- Model ranges include with or without a Dual-Line internal DACT.
- Compact, stylish enclosure.
- Available in Red or Grey.
- 2 Programmable NAC circuits with internal synchronization support.
- IP30 .

Added Features

SHIELD OMEGA with Internal Modem/DACT

- Dual line digital communicator & modem.
- Central Station reporting; SIA and Contact ID.
- On-board loop start terminal connections for both primary and secondary Telco lines.

SHIELD OMEGA with Ether/DACT

- Dual line digital communicator and modem.
- Central Station reporting; SIA and Contact ID.
- Phone line jacks – RJ-11 (two).
- Modem speed: 33.6 Kbps for program downloading.
- Virtual panel capability via Ethernet.

Note: Specifications are subject to change without notice

SHIELD OMEGA with Network Interface Card

- Upto 1.2 km between adjacent panels.
- 115 Kbps constant network speed.
- Total network delay less than 3 seconds with 64 panels.
- Mapped Network; Display messages for Any or All nodes.

SHIELD OMEGA with Media Gateway[®]

- All the features of the Ether/DACT and NIC plus.
- Enables network programming with direct TCP/IP access to each panel.

Technical Data	
Construction	16 AWG Sheet Steel
Finish (lid & box)	RAL3002 (Red) or BS00A05 (Grey)
Finish (product labels)	BS00A05 (Grey)
Mains Voltage Supply	230 V AC 50 or 60 Hz.
Mains Supply Fuse	1.6 A 250 V
Power Supply DC Rating	24 V 5.25 A
Aux 24V Supply	Fused at 500 mA
Battery (24 hour standby)	9 Ah 12 V (2 per panel) (non-networked)
Fault Contact Rating	3 0 V DC 1 A
Alarm Contact Rating	3 0 V DC 1 A
NAC Output Rating	3. 1 V Across Both Channels, 2.3 V Across Anyone
Detection Loop	250 mA Output
Serial Expansion Port	Serial RS485
PC Port	Serial RS232
Network Connection	Optional Network Cards Allow The Use Of SHIELD Omega-N Interface SA-EI
NAC Synchronization	Internal Support
NAC Protocols	System Sensor, Wheelock, Gentex, Amseco
Dimensions (W x H x D)	369 mm x 480 mm x 108 mm
Weight (without batteries)	9070 g
IP Rating	30

Ordering Information	
SR-P10R	Omega Single Loop Panel (RED)
SR-P10G	Omega Single Loop Panel (GREY)
SR-P2LR	Omega Two Loop Panel (RED)
SR-P2LG	Omega Two Loop Panel (GREY)

Note: Specifications are subject to change without notice

SA-P20R /SA-P4LR

2 Loops / 4 Loops

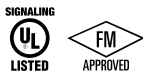

OMEGA-X Addressable Fire Alarm Control Panel

Product Overview

The SA-P20R and SA-P4LR analog addressable FACP supports 2 or 4 SLC loops for a total of 500 primary points or 800 points using subpoints. SLC loop communications uses standard twisted pair cabling, shielded cable is not necessary.

The panel may be configured with various communication cards; Communications options support central station monitoring, virtual panel, and networking. The panel can be configured as a stand alone panel with just a few devices for a small building, it can also operate as the building system and can be part of a network with a total of 64 nodes serving a multiple building campus or a very large facility.

Auto Learn capability provides a convenient method to troubleshoot new installations before final programming is loaded.

Standard Features

- UL 864 9th Edition listed.
- Multi-Loop 2 Analog Addressable Loops Field upgradable to 4.
- 126 primary points per loop.
- Powerful, network wide cause and effects (500 total).
- Fully user programmable by point or zone.
- 800 points per panel when using devices with sub-points.
- Up to 3048 m wiring length on SLC loop.
- 64 Panels on a network.
- Programmable through a PC connection to the panel, or through keypad.
- Programmable relays – 5.
- Supervised Powered Outputs – 3.
- 4 Programmable notification appliance circuits.
- Power per NAC: 1.6 A maximum.
- Programmable outputs on SLC loop.
- Programmable Function button on front display.
- Fire Drill button on front display.
- Day and night sensitivity settings (user programmable).
- Power Supply: 5.25 A regulated & integrated.
- LCD Display: 8x40.
- Zonal Mode: Annunciation by zone w/o individual relationships.
- Panel Ring Modes: Common, Zonal, and Stage 2.
- NAC Outputs programmable.
- Continuous, March, Temporal.
- Program cause and effects AND, OR, or any two (Cross Zone).
- Battery size: Up to 17 Ah in standard enclosure; up to 52 Ah with external cabinet.
- Access levels: 3.
- Access key switch: Yes.
- Recognized for use in High Rise Buildings.
- One-man walk test – Fire Test Mode.
- Available in Red.
- IP30.

Note: Specifications are subject to change without notice

SHIELD Omega-X with eNET

- Network uses standard RS485 cabling.
- Up to 1.2 km between adjacent panels.
- 115 Kbps constant network speed.
- Secure, fault tolerant communication.
- Up to 64 nodes.

SHIELD Omega-X with DACT

- Dual line digital communicator & modem.
- Contact ID and SIA reporting.
- UL 864 9th edition listed.
- Zone or point reporting.
- Backup and duplicate reporting.

Technical Data	
Primary AC	230 V AC @ 2 A, 50 or 60hz
Output DC	24 V DC @ 4 A
Power Supply	5.25 A Regulated and Integrated
Charger Current	1.25 A Max.
Finish (lid & box)	RAL3002 (Red) or BS00A05 (Grey)
Display	8 Line x 40 Character LCD (320 characters total)
Zones	500 Zones Per Network
SLC Loops	2 o r 4 (class A or B)
Devices Per Loop	126 Sensors & Modules (800 addresses + sub addresses max. per panel)
NAC Outputs	(4) 1.6 A @ 24 V DC (class B)
Relay Outputs	(5) Form C 1 A @ 30 V DC
Voltage Outputs	(3) 500 mA @ 24 V DC, Reverse Polarity Supervised
Aux. Power	500 mA @ 24 V DC
Aux. Inputs	(3) Digital Pull Downs
Current Consumption	
SA-P2OR	355 mA Standby 650 mA Alarm
SA-P4LR	455 mA Standby 765 mA Alarm
Dimensions (W x H x D)	369 mm x 610 mm x 127 mm
Weight (without batteries)	11400 g
IP Rating	30

Ordering Information	
SA-P2OR0	Omega-X Two Loop Panel (RED)
SA-P2OG0	Omega-X Two Loop Panel (GREY)
SA-P4LR0	Omega-X Four Loop Panel (RED)
SA-P4LG0	Omega-X Four Loop Panel (GREY)
SA-P2OR3	Omega-X Two Loop Panel With Printer
SA-P4LR3	Omega-X Four Loop Panel With Printer

Note: Specifications are subject to change without notice

SA-EVR

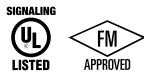

OMEGA R

Product Overview

Designed and manufactured to the highest standards in a quality controlled environment the SHIELD Omega-R fire alarm repeater provides a simple and convenient method of extending the controls and indications of the SHIELD Omega fire alarm control panel to other locations.

The large, graphic liquid crystal display and high brightness LED indicators duplicate the indications on the SHIELD Omega fire alarm control panel at up to 15 additional locations via a simple, two-wire serial data connection.

The SHIELD Omega-R is powered by 24 V DC (which can be via an additional 2 conductors from the control panel or local 24 V DC listed supply).

SHIELD Omega-R is housed in a small enclosure which is styled similarly to the SHIELD Omega control panel and is ideal for installations where a large control panel would be detrimental to décor such as entrance halls.

Up to 15 SHIELD Omega-R annunciators can be connected to each control panel on the Omega network making Omega-R ideal where multiple points of indication and/or control are required such as nurses stations or shop units.

Addressable Repeater Panel

Standard Features

- Available in Red.
- Up to 15 annunciators can be connected to each SHIELD Omega fire control panel.
- Large liquid crystal display (240 x 64 pixels).
- High brightness LED indications.
- Internal sounder.
- Replicates all panel controls.
- Simple, two-wire serial connection.
- Small, style enclosure.
- Removable electronics for easy installation.
- 24 V DC powered.
- Low power consumption.
- Multi language options.
- Connection supervised by SHIELD Omega fire control panel.

SHIELD Omega series control panel

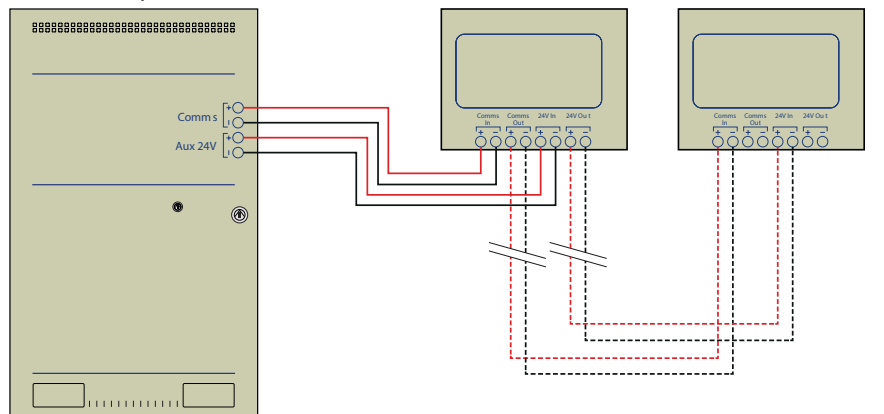

Note: Specifications are subject to change without notice

Technical Data

Construction	1.2 mm Mild Sheet Steel
Cable Entry	4 Knockouts In Back Of Box
Finish	RAL3002 (Red) or BS00A05 (Grey)
Power Supply DC Rating	21 to 30 V DC
Maximum Ripple Current	200 Millivolts
Quiescent Current Of Panel in Mains Fail	0.03 A
Serial Data Connection	2 Core RS485 (Up to 1200 metres total cable length)
Maximum Terminal Capacity	12 AWG
Dimensions (W x H x D)	263 mm x 191 mm x 42 mm
Weight	1600 g

Ordering Information

SA-EVR	Omega-R Repeater Panel (RED)
SA-EVG	Omega-R Repeater Panel (GREY)

Note: Specifications are subject to change without notice

LOCATOR

Graphical User Interface for Fire Detection Equipment



Product Overview

SHIELD fire control panels can send data to, and be controlled by, the LOCATOR system providing a single point of co-ordination for all alarms.

The powerful 32 bit programme features a standard Windows look and feel and runs under Windows® 2000 , XP, Vista or Windows 7 Professional. The system is highly configurable in terms of the style of presentation so that the end user can be presented with maps, text, photographs, audio or a combination of all as required.

User profiles allow the system manager to control the facilities available to each individual system user. A comprehensive history logging and reporting system allows analysis of events and trends to be identified to reduce unwanted alarms.

Easy to programme and simple to use, locator provides a cost effective solution for fire alarm management at many levels.

Standard Features

- Choice of text, graphic, event list display when an event occurs.
- Versatile event analysis.
- Total history archive.
- Easy to programme.
- Secure system.
- Cost effective compared to other systems.
- Simple to use.
- Unlimited map linking & zoom facility.
- Support for 100's of graphics.
- Display and control for multiple panels.
- Event history explore and export facility to text or HTML documents.



Fig 1. Powerful Event Log Filtering



Fig 2. Virtual Panel

Note: Specifications are subject to change without notice

Technical Specifications (Work Station)	
Processor	Intel Pentium 1 Ghz
Operating System	Windows® XP/Vista , 7 Professional
Memory	1 Gb Minimum
Hard Disk	10 Gb Minimum
Graphics	1024 x 768 16 M Colours
Sound Card	Any PC Sound Card
Loudspeaker	Any PC Speakers
Monitor	Any That Supports Above Graphics Driver
Pointing Device	Mouse Essential
Printer	Optional
Parallel Port	Optional
Serial Ports	One RS232 Per Network
CDROM Drive	Any
Backup Drive	CD Writer

Note: Locator will be operating 24 hours a day for many years. It may be desirable to include on site PC maintenance as part of the package. The SHIELD Omega panel to which the Locator system is connected must not have a printer fitted.

Ordering Information	
S1001	Locator Software - Single Panel Package
S1004	Locator Software - 4 Panel Package
S1008	Locator Software - 8 Panel Package
S1016	Locator Software - 16 Panel Package
S1032	Locator Software - 32 Panel Package
S1064	Locator Software - 64 Panel Package

Note: Locator for use with SHIELD Panels. SHIELD Omega 6 & 8 loop panels are considered 2 panels in the packages above.

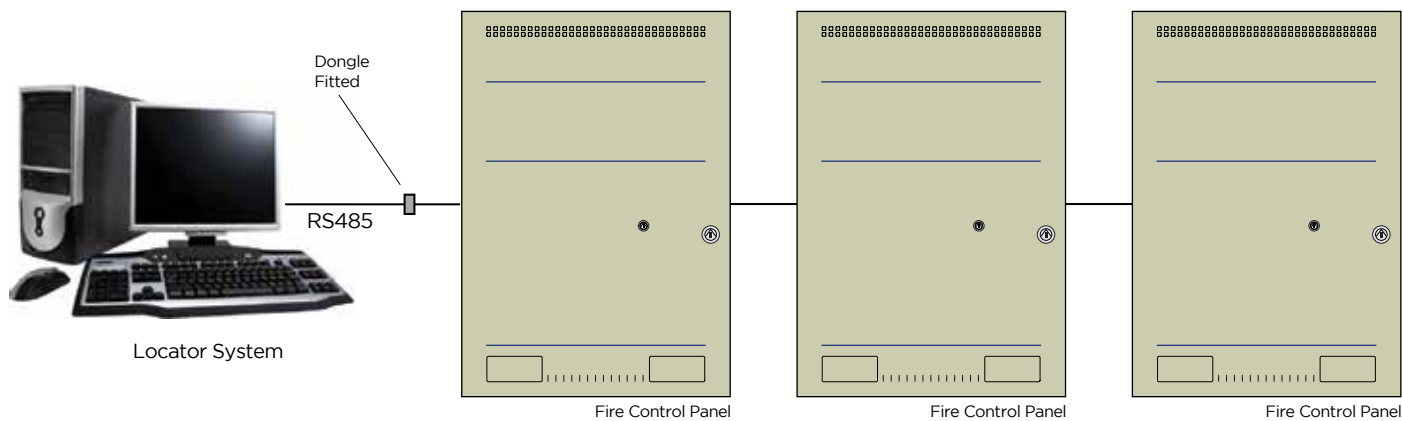

Note: Specifications are subject to change without notice

Open Connect

Gateway for Integration with Building Management System



Product Overview

Convenient incorporation of fire detection into your building management system without compromise.

Open Connect Gateway is an embedded device which sits between the Fire Alarm Control Panel and the BMS system.

Open Connect Gateway gets its Fire Alarm Information Via RS232 or RS485 from a special interface board located in one of the Fire Alarm Control Panel nodes. Open Connect Gateway can send its BMS information in a number of standard transmission methods to the BMS system.

Open Connect makes this possible without any unique software being written and using a simple, off-the shelf product.

The Open Connect Gateway takes the information from your fire alarm control panel and connects it to your building management system using standard BMS protocols. These include: Modbus , BACnet and LonWorks.

SHIELD Fire Alarm Control Panels using Shield Protocol are capable of integration with the Open Connect Gateway.

Standard Features

- Increased efficiency of system management.
- No modifications to fire detection and SLC devices.
- Integrity of fire alarm system assured.
- Reduced cost through standard software and single interface.
- Full system integration.
- Recurring engineering not required for each project.
- DIN-Rail mountable.

Accessories included

- 24 V AC / DC power supply.
- RS485 interface card.

Technical Specifications

Construction	16 AWG Sheet Steel
Finish (lid & box)	RAL3002 (Red) or BS00A05 (Grey)
Operating Temperature	32°F - 122°F (0°C to 50°C)
Operating Humidity	5% to 95% (non condensing)
Supply Voltage	230 V or 115V AC
Standby Batteries	2 x 12 V 12 Ah Sealed Lead Acid
Dimensions (W x H x D)	363 mm x 475 mm x 124.5 mm

Note: Specifications are subject to change without notice

Typical Design Layout

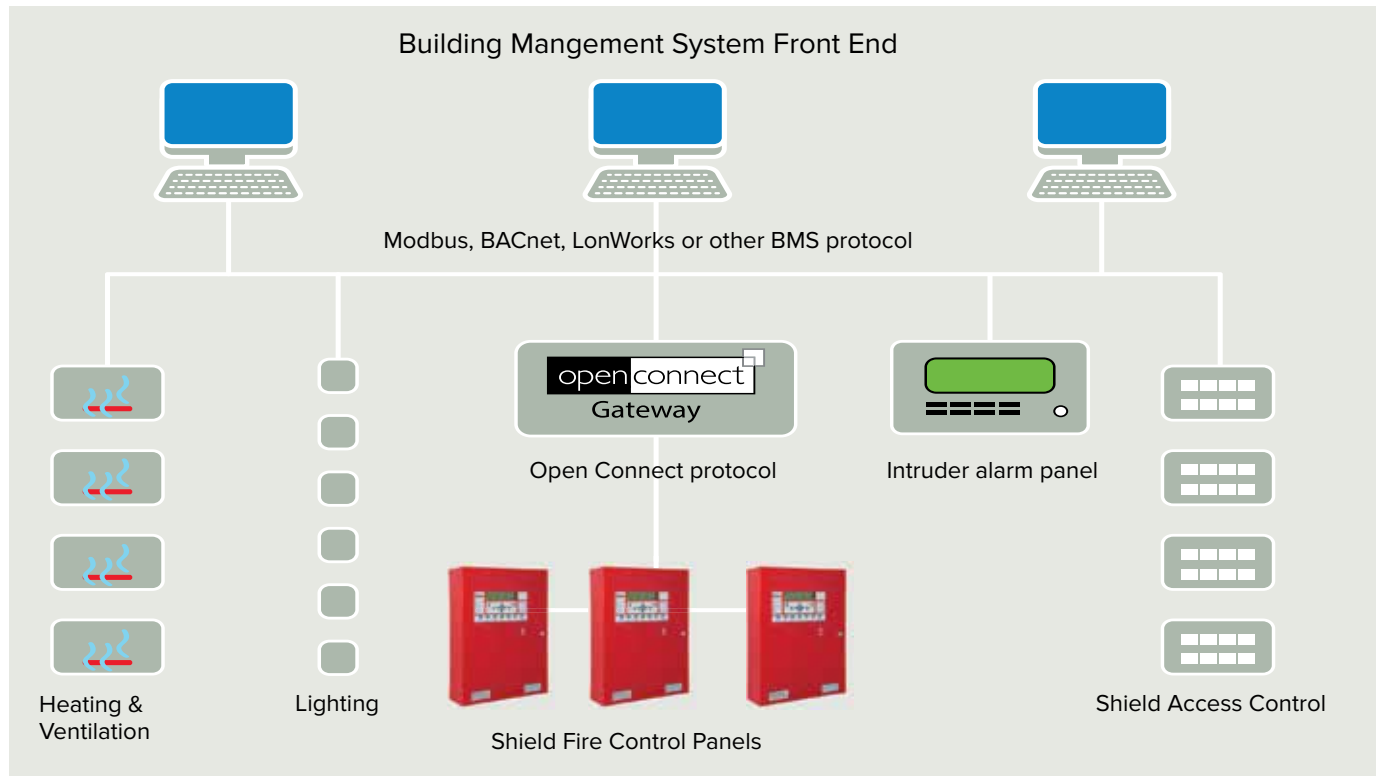

Ordering Information

Part Number	BACnet Points	BACnet Events	Modbus Points	Modbus Events	LonWorks Points	LonWorks Events	RS485 Serial Ports
SOC200-01	200	200	200	200	N/A	N/A	1
SOC200-02	200	200	200	200	N/A	N/A	2
SOC200-03	200	200	200	200	200	200	1
SOC200-04	200	200	200	200	200	200	2
SOC900-01	900	250	1400	300	N/A	N/A	1
SOC900-02	900	250	1400	300	N/A	N/A	2
SOC900-03	900	250	1400	300	1300	300	1
SOC900-04	900	250	1400	300	1300	300	2
SOC5500-01	5500	800	8800	1400	N/A	N/A	1
SOC5500-02	5500	800	8800	1400	N/A	N/A	2
SOC5500-03	5500	800	8800	1400	4096	1000	1
SOC5500-04	5500	800	8800	1400	4096	1000	2
SOC12000-01	12000	1800	10000	2000	N/A	N/A	1
SOC12000-02	12000	1800	10000	2000	N/A	N/A	2
SOC12000-03	12000	1800	10000	2000	4096	1000	1
SOC12000-04	12000	1800	10000	2000	4096	1000	2

Note:

Points are the number of fire system event that can be configured to be passed to the BMS.

Events are the maximum number of active events that can exist on the fire system that can be reliably passed to the BMS (if configured).

Note: Specifications are subject to change without notice



Omega - Network System Schematic

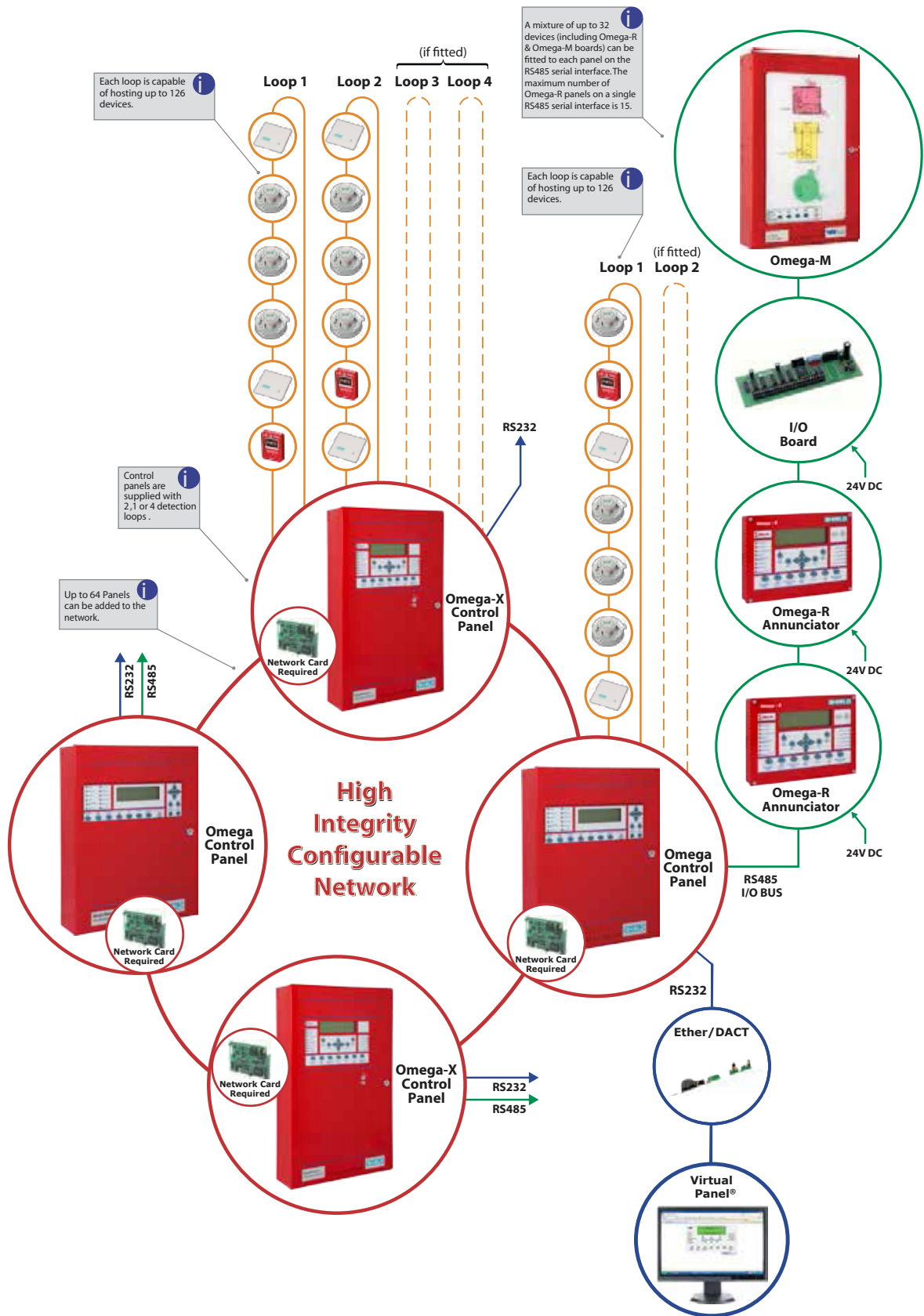

Note: Specifications are subject to change without notice

SHIELD[®]

TRUSTED WORLDWIDE

EXTINGUISHANT CONTROL SYSTEM

Shield A-XT is a new generation extinguishant releasing panel which is UL, FM listed. The simple, programmable configuration options and easy to install construction makes Shield A-XT panels the ideal choice for small to medium sized systems using all extinguishant agents.



SIGNALING



LISTED



APPROVED

- S230R-EXT
- S230G-EXT

S230R-EXT

Extinguishant Control Panel



Product Overview

Designed and manufactured to the highest standards in a quality controlled environment and with UL & FM approvals, the Shield A-XT releasing panel offers outstanding value and performance for all small to medium fixed fire fighting installations.

With three detection zones as standard, extinguishant release can be configured to activate from any combination of detection zone inputs to allow (among other combinations) any two from three type activations such as would be required for detection in ceiling void, room and floor void applications.

The extensive configuration options of the Shield A-XT allow the functionality of the system to be extensively modified. The panel contains a large LED display to enable easy configuration and control which also displays the time remaining until extinguishant release for added user safety. The countdown timer is duplicated on upto seven remote status units to provide local indication of the system status.

With all of the electronics mounted on a single, easily removable steel plate, Shield A-XT panels are both robust and easy to install. Shield A-XT is supplied in an enclosure, available in standard red or optional grey color.

Standard Features

- UL864 and FM listed.
- Three initiation circuits as standard.
- Any single zone or any combinations of zones can be configured to release.
- Configurable first stage NAC delays.
- Configurable detection delays.
- Zero time delay upon manual release option.
- Compatible with I.S. barriers.
- Non-latching zone input option to receive signals from other systems such as aspirating equipment.
- Configurable extinguishant delays upto 60 sec in 5 sec steps.
- Configurable extinguishant duration upto 5 min in 5 sec steps.
- Countdown timer shows time remaining until release.
- Supports up to seven, four wire status indicators.
- Built in Extract Fan control.

Access Level 2

- Test Zones 1 to 3.
- Disable Zones 1 to 3.
- Disable 1st Stage Alarms.
- Disable Pre-activated 1st Stage Relay.
- Disable Pre-activated 2nd Stage Relay.
- Disable Extract Fan Output.
- Disable Manual Release Input.
- Disable Extinguishant Sub System.
- Activate Extract Fan Output.
- Activate Alarm Delays.

Access Level 3

- Sounder Delay.
- Coincidence Detection.
- Disable Panel Features.
- Zone Alarm Delays (Detectors).
- Zone Alarm Delay (Call Points).
- Configure Zone for I.S Barrier Use.
- Zone Short Circuit Alarm.
- Zone Non Latching.
- Zone Inputs Delay.
- Extinguishant Release Time Delay.
- Extinguishant Release Duration Timer.
- Extinguishant Reset Delay Timer.

Note: Specifications are subject to change without notice

Technical Data

Construction	1.2 mm Mild Sheet Steel
IP Rating	IP30
Finish	Epoxy Powder Coated
Colour - Lid & Box	Red RAL 3002 (optional grey BS 00 A 05 semi-matt)
Mains Supply	230 V AC or 115 V AC
Mains Supply Fuse	1.6 A (F1.6 A L250 V)
Power Supply Rating	3 A Total Including Battery Charge 28 V +/- 2 V
Maximum Ripple Current	200 mV
Battery Charge Current	0.7 A Maximum
Battery Fuse	20 mm, 3.15 A Glass
Max. Current Draw From Batteries	3 A
Quiescent Current Of Panel In Mains Fail	0.095 A
Sounder Outputs	24 V Fused at 500 mA With Electronic Fuse
Fault Relay Contact Rating	30 V DC 1 A Amp Maximum
Fire Relay Contact Rating	30 V DC 1 A Amp Maximum
First Stage Contact Rating	30 V DC 1 A Amp Maximum
Second Stage Contact Rating	30 V DC 1 A Amp Maximum
Extract Contact Rating	30 V DC 1 A Amp Maximum
Zone Quiescent Current	2 mA Maximum
Terminal Capacity	12 AWG
Number Of Detectors Per Zone	Dependent On Type (maximum 32)
NAC Rating	0.5 A Per Circuit
Detection Circuit End Of Line	6 K 8 5% 1/2 Watt Resistor
Monitored Input End Of Line	6 K 8 5% 1/2 Watt Resistor
Sounder Circuit End Of Line	10 K 5% 1/2 Watt Resistor
Extinguishant Output EOL	1N4004 Diode
No. Of Initiating Circuits	3
No. Of NAC Circuits	2 x 1st Stage, 1 x 2nd Stage
Extinguishant Release Output	Fused at 1 A
Extinguishant Release Delay	Adjustable 0 to 60 Sec (in 5 sec steps)
Extinguishant Release Duration	Adjustable 60 to 300 Sec (in 5 sec steps)
SIL, AL, FLT, RST Inputs	Switched -ve, Max Resistance 100 Ohms
Zone Normal Threshold	8 K ohms to 1 K ohm
Detector Alarm Threshold	999 ohms to 400 ohms
Call Point Alarm Threshold	399 ohms to 100 ohms
Short Circuit Threshold	99 ohms to 0 ohms
Monitored Inputs Normal Threshold	8 K ohms to 1 K ohm
Monitored Inputs Alarm Threshold	999 ohms to 100 ohms
Monitored Inputs Short Circuit Threshold	99 ohms to 0 ohms
Status Unit/Ancillary Board Connection	Two Wire RS485 Connection
Status Unit Power Output	Fused at 500 mA With Electronic Fuse

Note: Specifications are subject to change without notice

Ordering Information

S115R-EXT	115V Surface Mounting Panel - Red
S230R-EXT	230V Surface Mounting Panel - Red
S115G-EXT	115V Surface Mounting Panel - Grey
S230G-EXT	230V Surface Mounting Panel - Grey

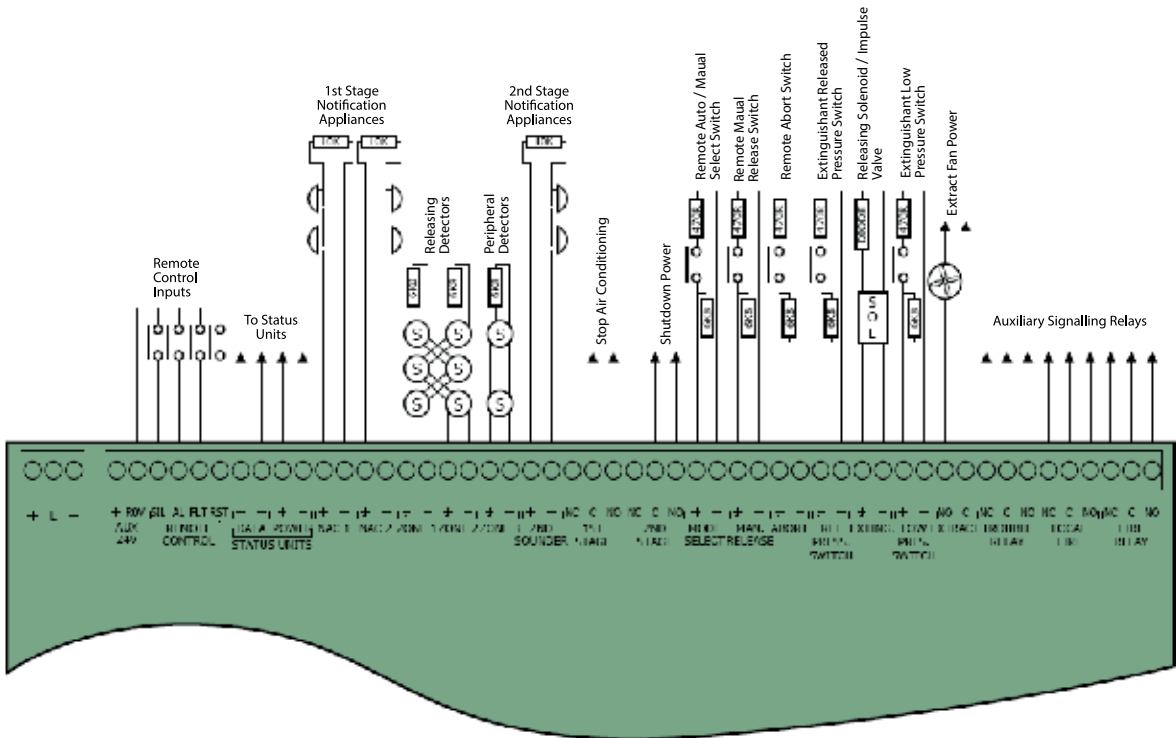

S111R-AB

Abort Switch



Product Overview

The abort switch connects to the abort terminals of the Shield releasing panel. Any number of Shield abort switches may be connected to the circuit. The last switch must have the end of line device from the abort circuit terminals of the Shield releasing panel fitted across its connections to provide open and short circuit supervision. The unit is supplied mounted to a rugged steel enclosure but may also be flush mounted to a single gang electrical box.

Technical Data

Construction	1.2 mm Mild Sheet Steel - IP30
IP Rating	Red (optional grey)
Colour	1 A at 30 V DC
Switch Rating Trigger Resist	470 R 1 W
End Of Line Resistor	6 K 8 1/2 W
Dimensions (W x H x D)	125 mm x 120 mm x 100 mm
Weight	475 g

Note: Specifications are subject to change without notice

SHIELD[®]

TRUSTED WORLDWIDE

VOICE EVACUATION SYSTEM

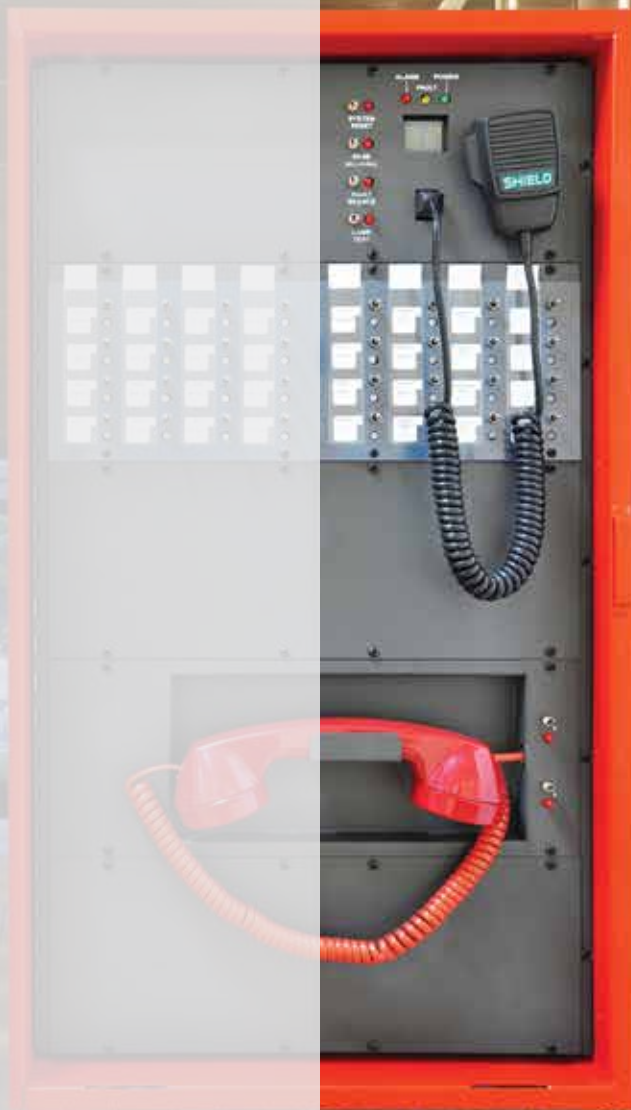

SIGNALING



LISTED

- SHX-MP
- SHX-DP

SHX-MP / SHX-DP

Master and Distributed Panel



Product Overview

The SHX Voice Evacuation System operates in conjunction with the Fire Alarm Control Panel (FACP) in a building to provide automatic response to life safety emergencies.

The SHX includes all necessary features to provide an effective voice evacuation system. It can be custom configured to satisfy the needs of any high rise application.

Fire department authorities can easily take command of evacuation or relocation procedures and emergencies. Building management and fire brigades can monitor and control emergency response even before the professionals arrive. The SHX system includes capacity for 6 channels of simultaneous audio. This provides evacuation messages for stay-in-place, or other public address announcements and automatic messages.

Fire Fighter Phones or Warden Stations may be included as required. Area of rescue stations can reassure handicapped occupants that help is on the way.

Standard Features

- True Multiplex 6 Channel Distributed Audio.
- Integrated Fire Phone capability.
- Modular System - components added as needed.
- Integrated 2 Channel Digital Message Repeater.
- Live Microphone Page to any zone.
- Fast RS-485 Communication Protocol.
- Fully Supervised.
- Easy Installation and Operation.
- Natural Sound Voice Recordings.
- Built in Alarm and Alert Signals.
- Upto 4 Minute Message Capacity.
- Works with 12 V DC or 24 V DC Fire Alarm Panel.
- Works with Analog/Addressable and Microprocessor based Fire Alarm Panels.
- 3 Minute Message Restart on Microphone Key.

Note: Specifications are subject to change without notice

SHX True-Multiplex System Capabilities

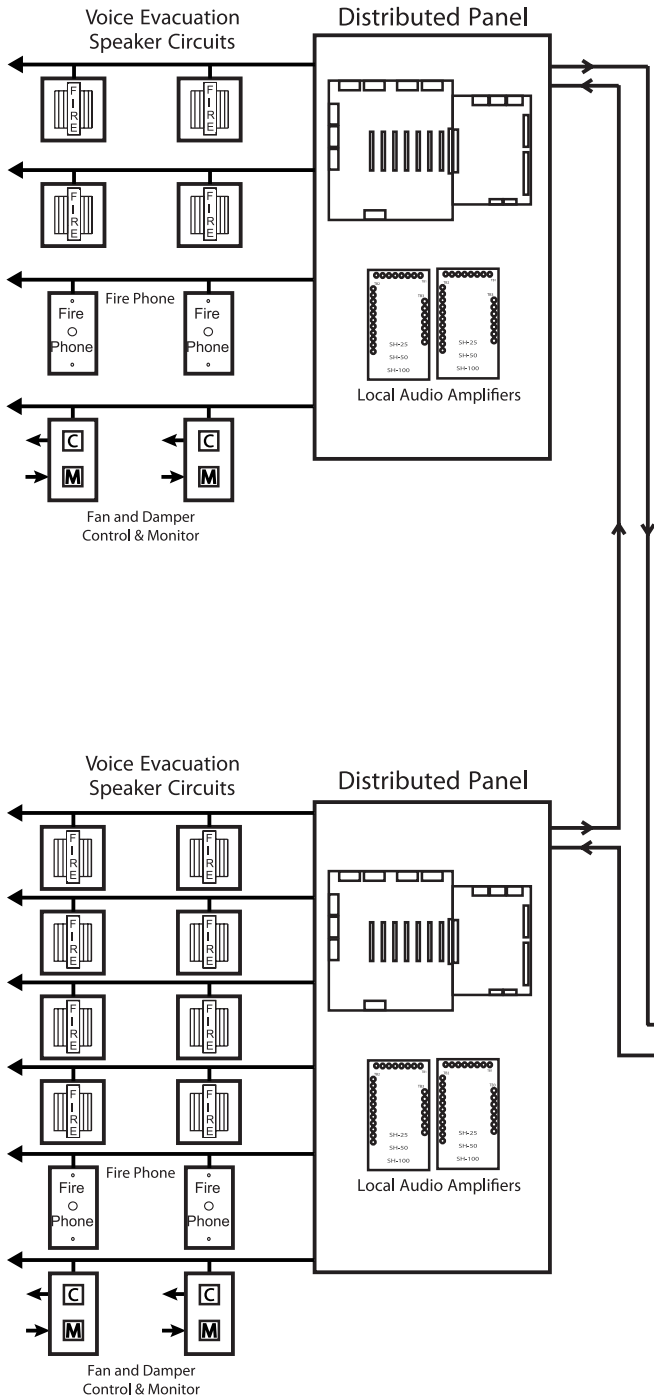

NetComm Loop

- Twisted Pair, Category 5.
- 1219 m between panels.
- 15240 m total System Loop.
- Data and 6 Audio Channels Simultaneously.
- High speed RS485 Communications.
- Style "4" or Style "7" Field Selectable.

System Configuration

Basic System Includes

- Master Panel (SHX-MP).
- Master Mic Control.
- 16 switch control points (max 128).
- Dual channel DMR.
- High speed communication loop.
- Distributed Panel (SHX-DP).
- 4 output zones (may be configured for 8).
- Dual channel Audio Interface.
- Dual Channel Amplification.

Optional

- Integrated Fire Phone.
- Area-of-Rescue.
- Number of distributed panels to be determined by building specifications.
- Maximum system configuration - Up to 250 Distributed Panels (SHX-DP) and up to 1000 switch points.

Master Panel

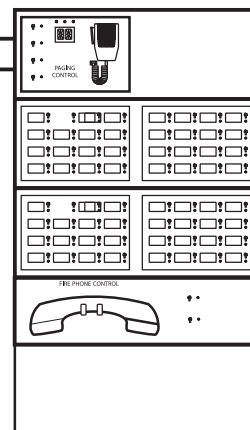

Note: Specifications are subject to change without notice

Technical Data

Primary Power	220 V AC
Battery Power	24 V DC
Electrical Ratings	All Circuits @ 24 V DC
Communications Bus	Rs485 Standard 1M Baud Data Rate, Category 5 Cable
Voltage	5 V Peak-To-Peak Max
Current	50 mA Max
Impedance	120 Ohms
Frequency	1.024 Mhz
Colour	Red
Back Box Dimensions (H x W x D)	686 mm x 368 mm x 102 mm

Ordering Information

SHX-MP16	Master Panel, 16 Selector Switch
SHX-MP32	Master Panel, 32 Selector Switch
SHX-MP48	Master Panel, 48 Selector Switch
SHX-MP64	Master Panel, 64 Selector Switch
SHX-MP80	Master Panel, 80 Selector Switch
SHX-MP96	Master Panel, 96 Selector Switch
SHX-MP16/P	Master Panel, 16 Selector Switch and Master Fire Phone
SHX-MP32/P	Master Panel, 32 Selector Switch and Master Fire Phone
SHX-MP48/P	Master Panel, 48 Selector Switch and Master Fire Phone
SHX-MP64/P	Master Panel, 64 Selector Switch and Master Fire Phone
SHX-MP80/P	Master Panel, 80 Selector Switch and Master Fire Phone
SHX-MP96/P	Master Panel, 96 Selector Switch and Master Fire Phone
SHX-DPS25	Distributed Panel, Single Channel, 25 W
SHX-DPS50	Distributed Panel, Single Channel, 50 W
SHX-DPS100	Distributed Panel, Single Channel, 100 W
SHX-DPS25/P	Distributed Panel, Single Channel, 25 W, and Fire Phone
SHX-DPS50/P	Distributed Panel, Single Channel, 50 W, and Fire Phone
SHX-DPS100/P	Distributed Panel, Single Channel, 100 W, and Fire Phone
SHX-DP25	Distributed Panel, Dual Channel, 25 W
SHX-DP50	Distributed Panel, Dual Channel, 50 W
SHX-DP100	Distributed Panel, Dual Channel, 100 W
SHX-DP25/P	Distributed Panel, Dual Channel, 25 W, and Fire
SHX-DP50/P	Distributed Panel, Dual Channel, 50 W, and Fire Phone
SHX-DP100/P	Distributed Panel, Dual Channel, 100 W, and Fire Phone

Note: Specifications are subject to change without notice

SH-FS / SH-WS

Fire Phone Equipments



Product Overview

The Fire Fighter Telephones are designed to operate in conjunction with the SHX Voice Evacuation System. These telephone handsets are permanently installed throughout a building to allow Fire Fighters easy communication with the main control panel. The SH-FS Fire Fighter telephone stations and SH-WS Warden Stations provide a handset in an enclosure. These fixed telephone and warden stations are available in surface or flush mount cabinet.

In addition to the Fire Fighter telephone stations, SHIELD provides portable Fire Fighter telephone handsets which plug-in to permanently installed telephone jacks throughout the building. Plugging in the portable handset allows the Fire Fighters to communicate with the main control panel. As with the permanently installed telephones, these portable handsets are made from durable ABS plastic and come equipped with a coiled cord and a male phone plug which plugs into the Fire Fighter's telephone jack.

Standard Features

- Heavy-duty construction.
- Red finish.
- Flush or surface mount.
- Rugged ABS plastic handset with coiled cord.
- Portable handsets and telephone jacks (optional).

Station Back Box (Surface Mount)	
Dimension (H x W x D)	324 mm x 185 mm x 96 mm

Ordering Information	
SH-FS	Telephone Station (coiled cord and magnetic catch)
SH-WS	Warden Station (armored cable and magnetic catch)

Note: Specifications are subject to change without notice

SH-TC

Fire Phone Storage Cabinet



Description

The SH-TC Storage Cabinet holds up to six portable SH-FH telephone handsets. The SH-TC is a surface mount enclosure and comes with a key locked door.

Storage Cabinet

Dimension (H x W x D)	686 mm x 368 mm x 102 mm
-----------------------	--------------------------

SH-FH & SH-FJ

Fire Fighter’s Portable Handset & Fire Fighter’s Jack



Product Overview

The red portable telephone handset comes with a coiled cord and a male phone plug which plugs into the SH-FJ Fire Fighter’s Telephone Jack, allowing Fire Fighters to make direct communication with the main control panel. The Fire Fighter’s Telephone Jack consists of a single phone jack which is mounted on a single gang, stainless steel plate. The stainless steel plate is clearly marked “FIREMAN PHONE” and mounts to any standard single gang box.

Ordering Information

SH-TC	Telephone Handset Storage Cabinet
SH-FH	Fire Telephone Handset
SH-FJ	Fire Telephone Jack

Note: Specifications are subject to change without notice

SHIELD[®]

TRUSTED WORLDWIDE

VOICE EVACUATION SPEAKERS

- Ceiling Speaker
- Wall Speaker



SSPK-C2000 / SSPK-W2000

Ceiling Speaker / Wall Speaker



Shield's 4" Speakers are designed for broadcasting high quality tone signals and are ideal for alarm signaling in hotels, malls, apartments and other areas where attractive appearance and dependable performance are prime concerns.

These 4" Speakers consist of a loudspeaker, 6 oz. magnet, a low profile constant voltage line matching transformer, a D.C. blocking capacitor and an all steel speaker baffle finished in an off white colour. The 25 and 70 volt transformers are of the matching type and include output power taps of ¼, ½, 1 and 2 watt(s). Tap selection is made by wiring into the appropriate slot on the speaker's terminal block. The Shield speakers install easily using the surface or flush backboxes.

These voice evacuation speakers are specially designed for high quality emergency fire alarm signals and voice communication. These units must be used with Shield's SHX Voice Evacuation System or any voice alarm equipment approved by Underwriters Laboratories (UL).

Standard Features

- 25 & 70 volt line matching transformers.
- High dBA output (over 90 dBA at 10 feet @ 2 watts).
- D.C. blocking capacitor for line supervision.
- Terminal block connection for speaker tap/output selection.
- Multiple output taps. Selection for ¼, ½, 1 or 2 watts.
- Moisture resistant.
- Fire retardant cone material.
- Factory assembled and tested.
- Each speaker is equipped with a ground wire.
- Off white speaker baffle.
- Round or square baffles.

Specifications

Model Number	Voltage	SPEAKER dBA 10 FT.				Mounting Configurations		Baffle Shape
		WATT TAP				Flush	Surface	
		¼ WATT	½ WATT	1 WATT	2 WATT			
SSPK-C2000	70	85	86	89	91	SSPK-C2050	N/A	ROUND
SSPK-W2000	70	85	86	89	91	SSPK-W2050	N/A	SQUARE

Note: Specifications are subject to change without notice

Installation Instructions

dBA Sound Pressure Level is measured using the transformer tap shown at a distance of 10 feet (3 meters). This measurement is obtained in accordance with ULC Standard ULC-S541-M87.

NOTE: All Shield enclosures are equipped with a ground screw hole. Each speaker unit is equipped with a ground wire.

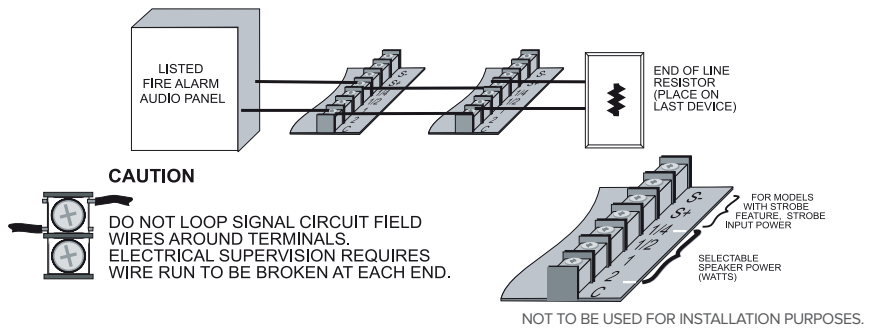
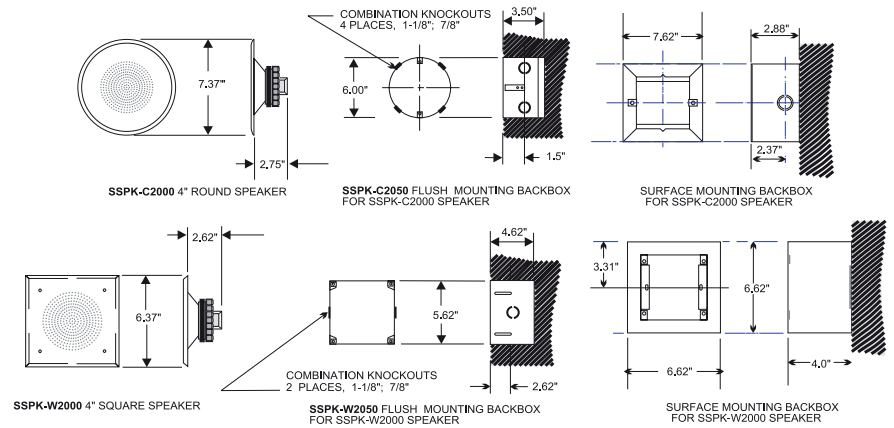

Wiring Instructions

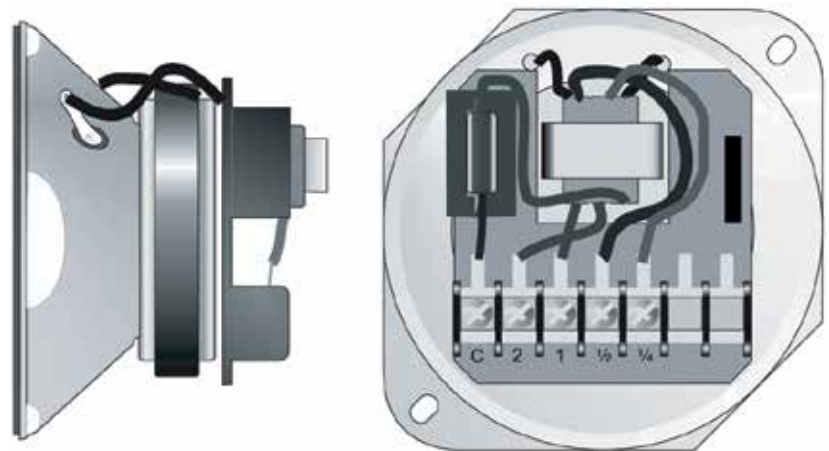

Desired wattage is selected by wiring into the corresponding terminal on the speaker terminal block.

SHIELD®

TRUSTED WORLDWIDE

SHIELD[®]
TRUSTED WORLDWIDE

SHIELD FIRE, SAFETY & SECURITY LTD

Unit 3, Endeavour Drive, Basildon-Essex, SS14 3WF, United Kingdom
Tel: +44 1708 377731 Fax: +44 1708 347637, E-mail: Shielduk@shieldglobal.com
www.shieldglobal.com