



**OPEN SPRINKLER
SYSTEM**

SHIELD

Trusted Worldwide



Introduction

Competence and innovation driven by consistent market development and customer requirements have shaped the successful development of the SHIELD Brand. The extensive product range of the market leader in the field of fire protection technology contains single, individually integrable system performances. In this way, a customized overall fire protection concept can be planned and realized for every need with optimally synchronized products.

Performance is in international demand, SHIELD is among the highly accredited fire protection companies that meet rigorous British and American standards for all projects from small conventional system to multi site networks. Certifications such

as UL and FM approvals have earned SHIELD a world-renowned reputation with quality products and powerful solutions.

A strong brand is generally known to be a secure basis for close and lasting customer relationships. In accordance with this, SHIELD uses available potential in order to keep on growing in a dynamic competitive environment. And at the same time, SHIELD stands for innovative and high quality fire protection systems.

We invite you to explore and visit our website www.shieldglobal.com. You can also send us your feedback and inquiry through our user-friendly online forms.

OPEN TYPE SPRINKLER SYSTEM

Open type Sprinkler System is kind of deluge sprinkler system. Open sprinklers attached to a piping system connected to a water supply through deluge valve opened by the operation of a detection system. A complete open type sprinkler system includes sprinkler, deluge valve, infrared flame detector, central control panel, local control panel and pump. Mainly apply to atrium or large volume, non-compartmented spaces of residence, hotel, shopping mall, exhibition hall, stadium and other similar buildings for quick detection and effective extinguish.

SYSTEM DIAGRAM

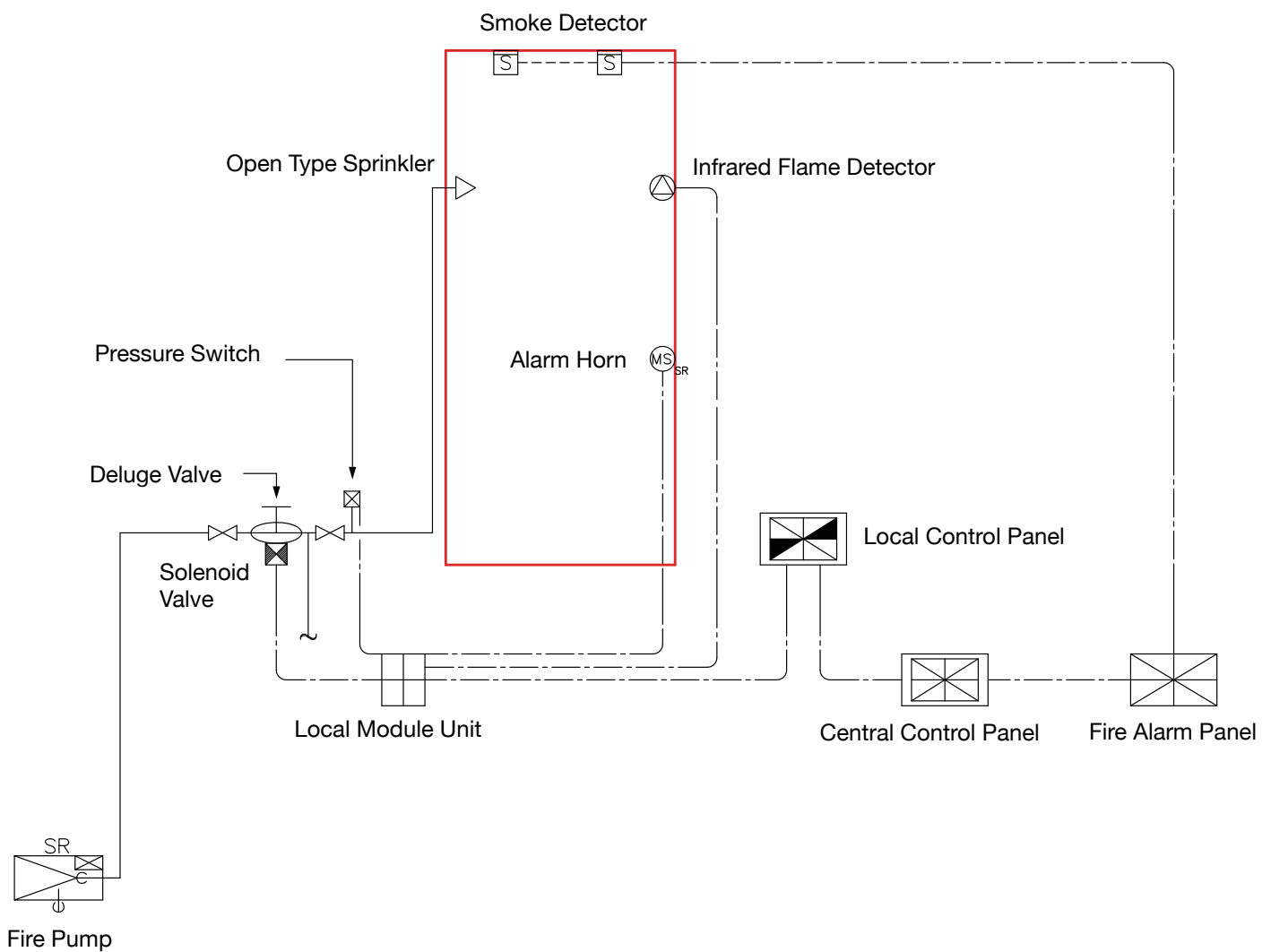



PRODUCT LIST

According to the architectural features of the large volume space, select the suitable open type sprinkler as follows. All open type sprinklers are fixed type.

Type	Model No.	Working Pressure (MPa)	Flow Rate (LPM)	Installation Height (m)	Coverage
Pendent 	SD-4010PS	0.25~0.50	120~170	2~18	16m ² (Dia 4.6m)
	SD-4020PS	0.25~0.50	300~425	6~18	50m ² (Dia 8.0m)
	SD-4030PS	0.25~0.50	475~675	6~18	78m ² (Dia 10m)
	SD-4040PS	0.25~0.50	1000~1410	6~18	176m ² (Dia 15m)
	SD-4050PS	0.25~0.40	1800~2275	6~18	254m ² (Dia 18m)
	SD-4060PS	0.25~0.40	2535~3210	6~18	380m ² (Dia 22m)

Type	Model No.	Working Pressure (MPa)	Flow Rate (LPM)	Installation Height (m)	Coverage
Sidewall 	SD-6040SW	0.35~0.50	385~460	5~11	77m ² [11m x 7m (L x W)]
	SD-6050SW	0.35~0.50	560~665	6~16	112m ² [16m x 7m (L x W)]
	SD-6060SW	0.35~0.50	530~632	6~16	105m ² [21m x 5m (L x W)]
	SD-5030SW	0.35~0.50	350~420	3~5	57m ² [8.16m x 7m (L x W)]
		0.35~0.50	350~420	5~13	64m ² [9.16m x 7m (L x W)]
	SD-5040SW	0.35~0.50	410~488	3~5	64m ² [9.16m x 7m (L x W)]
		0.35~0.50	410~488	5~13	71m ² [10.16m x 7m (L x W)]
	SD-5050SW	0.35~0.50	550~655	3~13	68m ² [17.16m x 4m (L x W)]

CLEARANCE

Clearance for the open type sidewall sprinklers are as follows:

Model No.	Minimum Clearance above the deflector
SD-6040SW	2.0 m
SD-6050SW	3.0 m
SD-6060SW	4.0 m
SD-5030SW	0.5 m
SD-5040SW	0.5 m
SD-5050SW	2.0 m



Model No.: SD-4010PS



Coverage

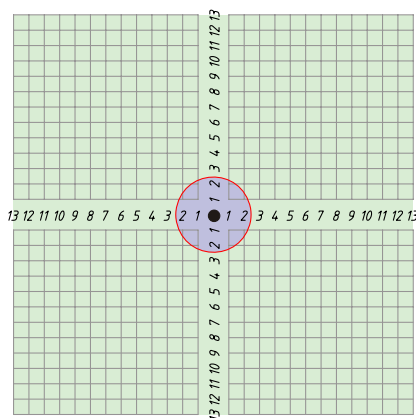

Distance (m)

Top View

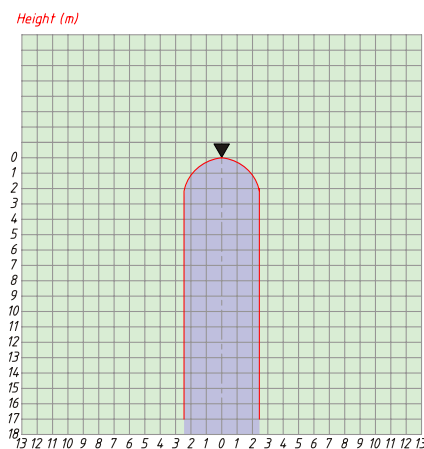

Height (m)

Distance (m)

Side View

Specification	
Type	Pendent
K Factor	5.4
Working Pressure	0.25~0.50 MPa
Flow Rate	120~170 LPM
Installation Height	2~18 m
Coverage	16 m ²
Thread Connection	R 1/2"

Model No.: SD-4020PS



Coverage

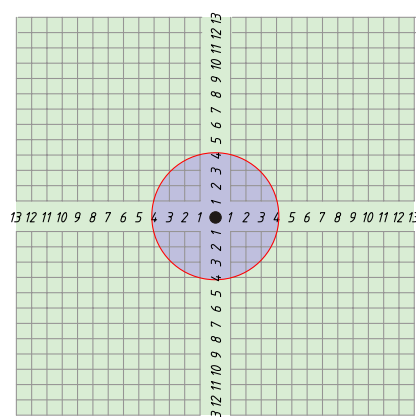

Distance (m)

Top View

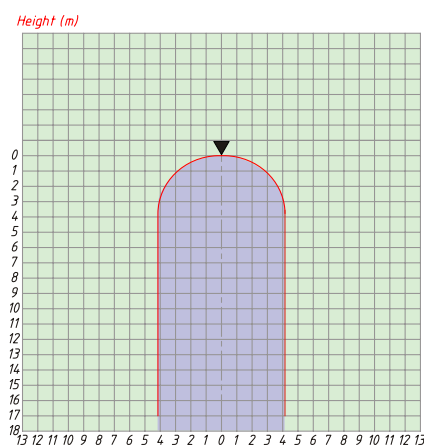

Height (m)

Distance (m)

Side View

Specification	
Type	Pendent
K Factor	13.4
Working Pressure	0.25~0.50 MPa
Flow Rate	300~425 LPM
Installation Height	6~18 m
Coverage	50 m ²
Thread Connection	R 1"



Model No.: SD-4030PS

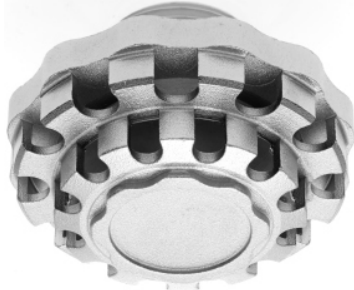

Coverage

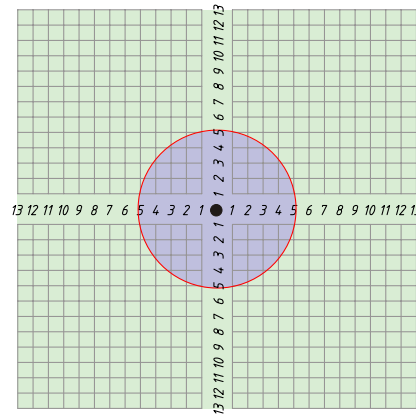

Top View

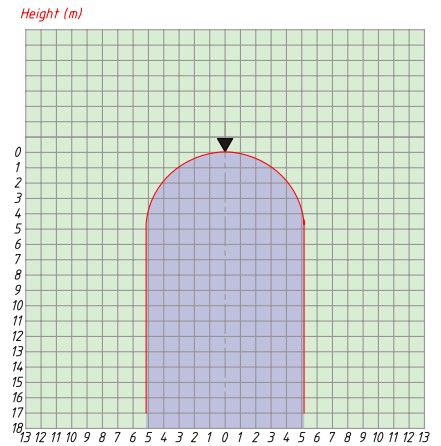

Side View

Specification	
Type	Pendent
K Factor	20.3
Working Pressure	0.25~0.50 MPa
Flow Rate	475~675 LPM
Installation Height	6~18 m
Coverage	78 m ²
Thread Connection	R 1"

Model No.: SD-4040PS



Coverage

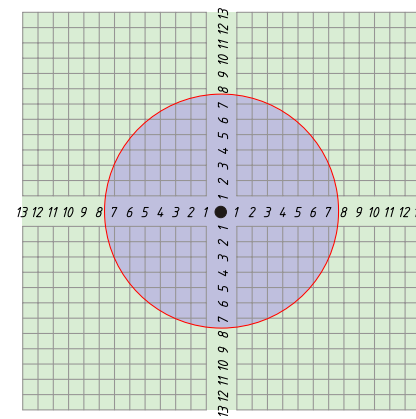

Top View

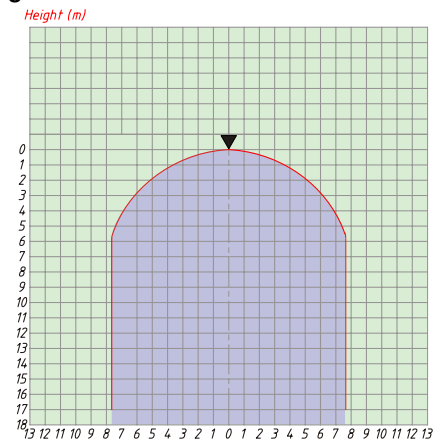

Side View

Specification	
Type	Pendent
K Factor	44.3
Working Pressure	0.25~0.50 MPa
Flow Rate	1000~1410 LPM
Installation Height	6~18 m
Coverage	176 m ²
Thread Connection	R 1 1/2"



Model No.: SD-4050PS



Coverage

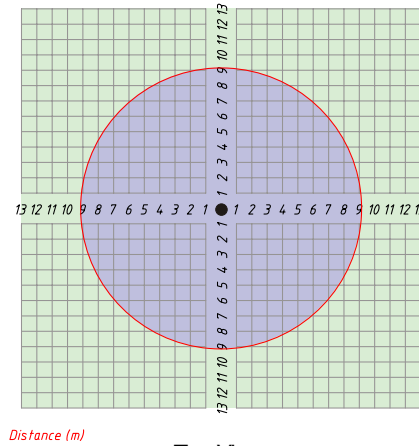

Top View

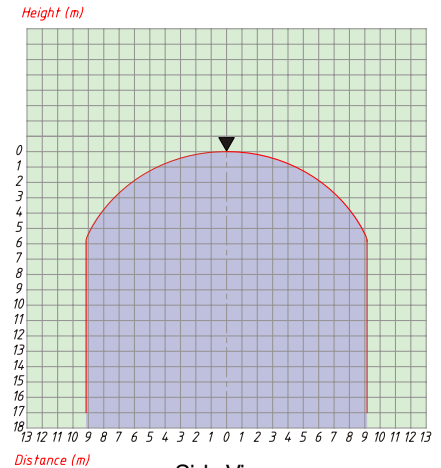

Side View

Specification	
Type	Pendent
K Factor	79.8
Working Pressure	0.25~0.50 MPa
Flow Rate	1800~2275 LPM
Installation Height	6~18 m
Coverage	254 m ²
Thread Connection	R 2"

Model No.: SD-4060PS



Coverage

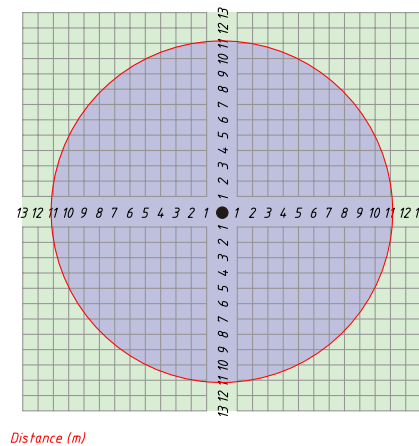

Top View

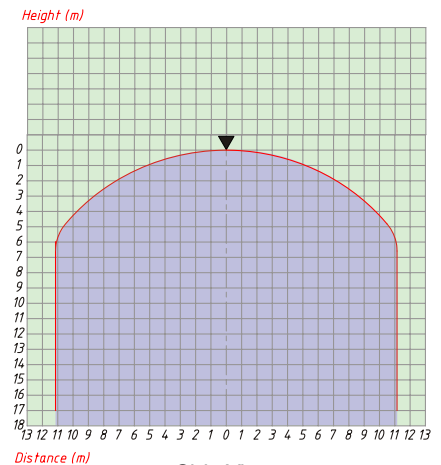

Side View

Specification	
Type	Pendent
K Factor	112.5
Working Pressure	0.25~0.50 MPa
Flow Rate	2535~3210 LPM
Installation Height	6~18 m
Coverage	380 m ²
Thread Connection	R 2 1/2"



Model No.: SD-5030SW

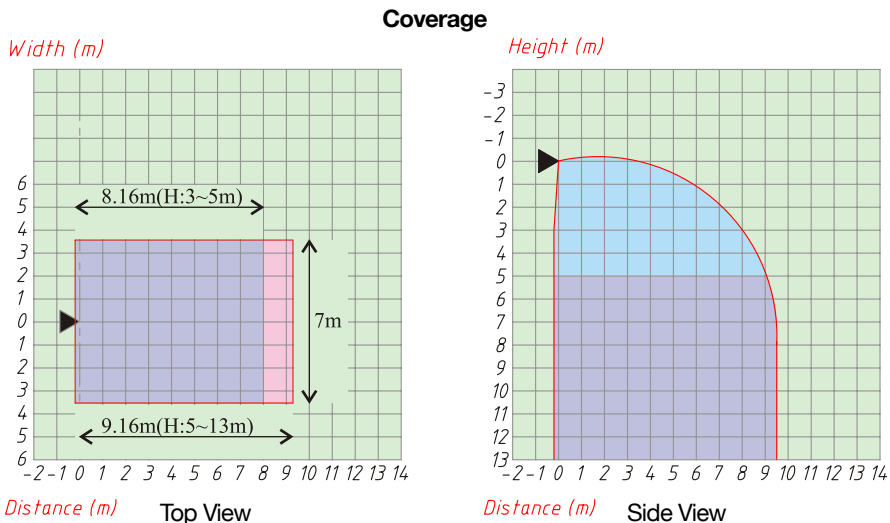

Specification	
Type	Sidewall
K Factor	13.5
Working Pressure	0.35~0.50 MPa
Flow Rate	350-420 LPM
Installation Height	3~13 m
Coverage	3~5 m - 57 m ² ; 5~13 m - 64 m ²
Thread Connection	R 1"

Model No.: SD-5040SW

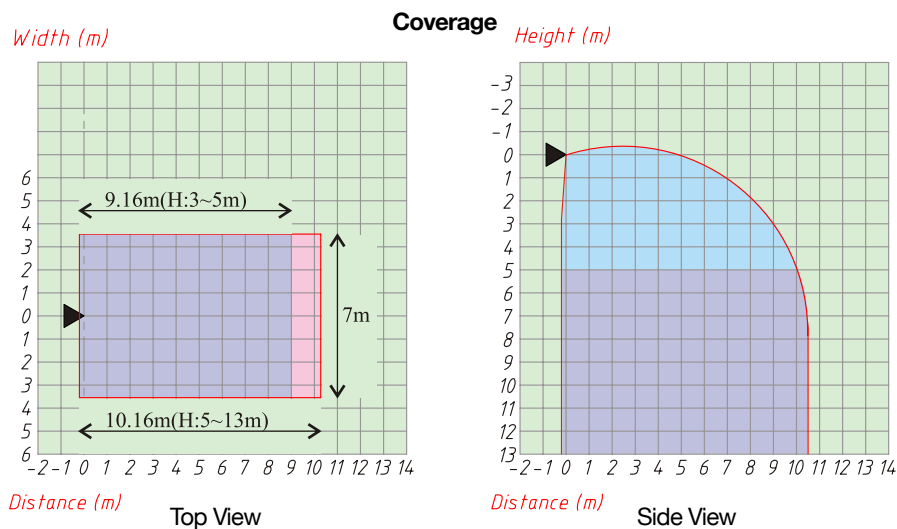

Specification	
Type	Sidewall
K Factor	15.6
Working Pressure	0.35~0.50 MPa
Flow Rate	410-488 LPM
Installation Height	3~13 m
Coverage	3~5 m - 64 m ² ; 5~13 m - 71 m ²
Thread Connection	R 1"



Model No.: SD-6040SW

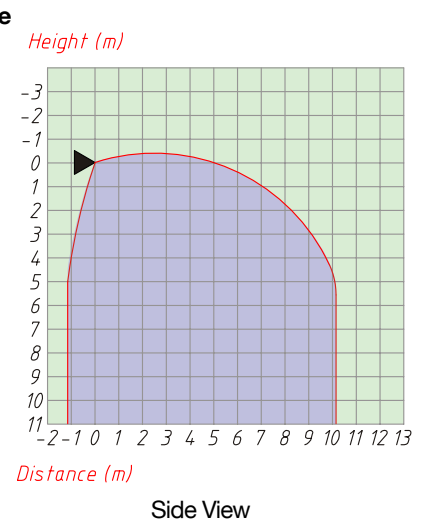
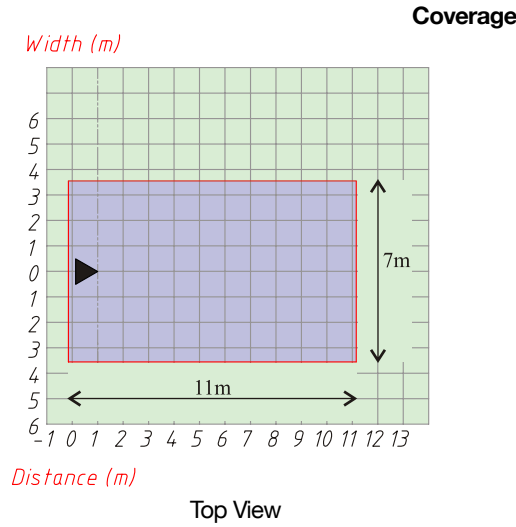

Specification	
Type	Sidewall
K Factor	15
Working Pressure	0.35~0.50 MPa
Flow Rate	385-460 LPM
Installation Height	5~11 m
Coverage	77 m ²
Thread Connection	R 1 1/2"

Model No.: SD-6050SW

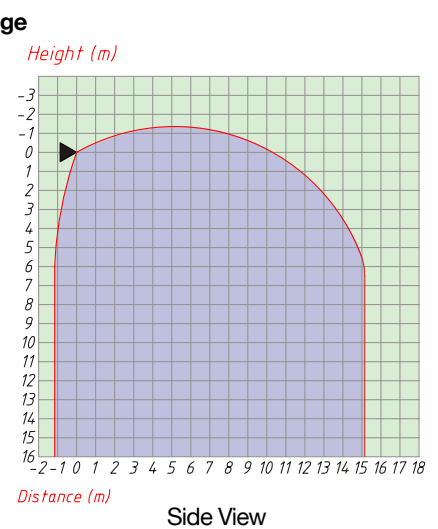
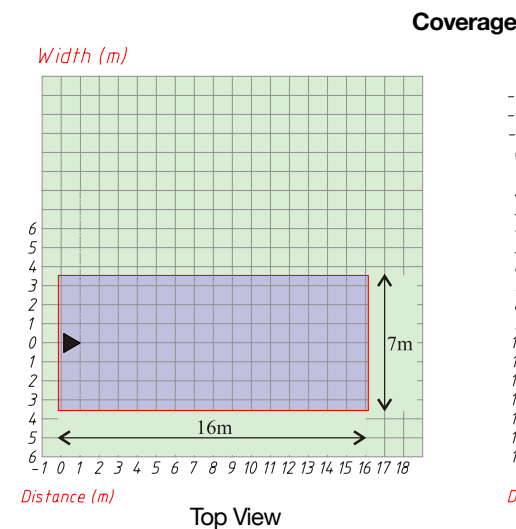

Specification	
Type	Sidewall
K Factor	20.9
Working Pressure	0.35~0.50 MPa
Flow Rate	560-665 LPM
Installation Height	6~16 m
Coverage	112 m ²
Thread Connection	R 1 1/2"



Model No.: SD-6060SW



Width (m)

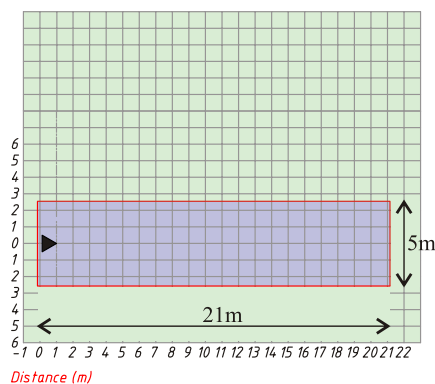

Top View

Coverage

Height (m)

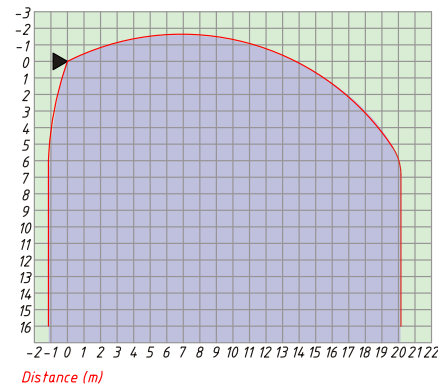

Side View

Specification	
Type	Sidewall
K Factor	23.9
Working Pressure	0.35~0.50 MPa
Flow Rate	635-904 LPM
Installation Height	6~16 m
Coverage	105 m ²
Thread Connection	R 2 1/2"

Model No.: SD-5050SW

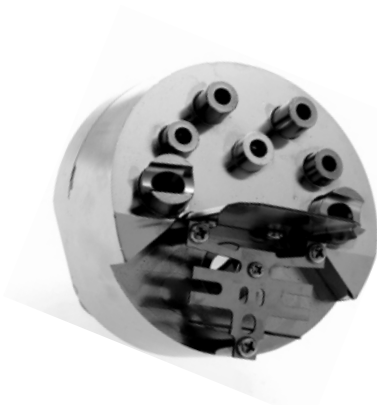

Width (m)

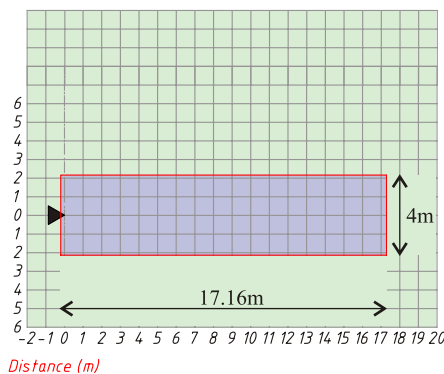

Top View

Coverage

Height (m)

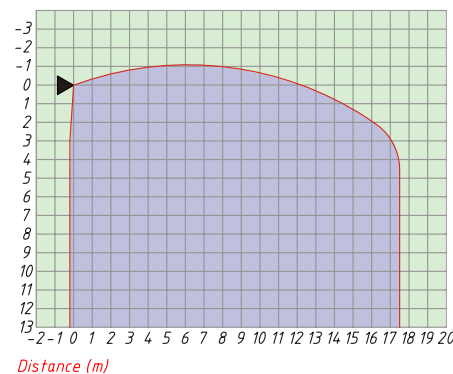

Side View

Specification	
Type	Sidewall
K Factor	21
Working Pressure	0.35~0.50 MPa
Flow Rate	550-655 LPM
Installation Height	3~13 m
Coverage	68 m ²
Thread Connection	R 2"

ALARM VALVE

MODEL: SDH-AVA



Alarm Valve is a double seated clapper check valve with grooved seat design, which ensures positive water flow for alarm operation and is designed for installation in wet pipe sprinkler system. External bypass prevents false alarm under all supply pressure condition. In the event of variable pressure condition, false alarm is prevented with the provision of retard chamber, thus the design allows for installation under both variable and constant supply pressure condition.

Operation of one or more automatic fire sprinklers causes the water to flow into the sprinkler system causing the alarm valve to open, allowing continuous flow of water into the system and transmittal of alarm, both electrical and mechanical.



NOMINAL SIZE	200, 150, 100, & 80 NB
MATERIAL	Ductile Iron
END CONNECTION	Flange X Flange
MAXIMUM WORKING PRESSURE	17.5 Bar (250 PSI)*
MOUNTING	Vertical
FLANGE CONNECTION	ANSI B16.42 #150 (Flange drilling matching to ANSI B 16.5 #150)
FINISH	Red RAL 3000

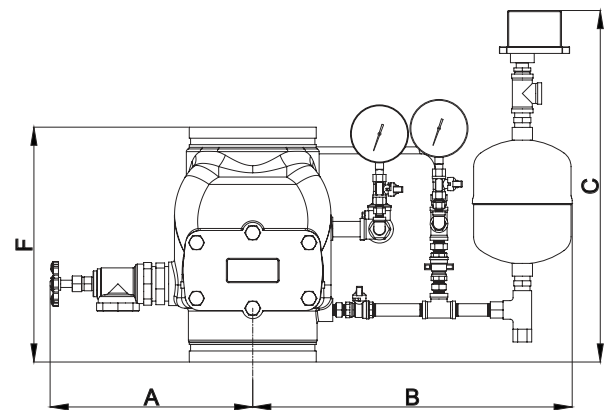
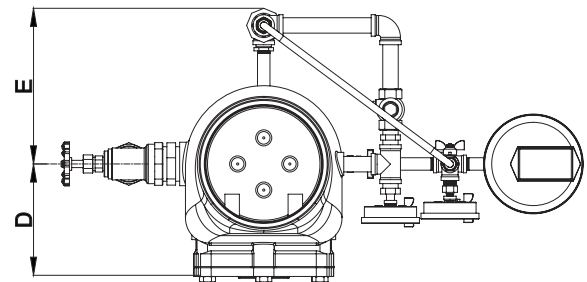

WITH VARIABLE PRESSURE TRIM				
SIZE	80 NB	100 NB	150 NB	200 NB
A	279	312	331	350
B	482	488	510	551
C	588	588	588	597
D	127	140	173	204
E	201	219	234	269
F	280	300	324	405

Unit : mm

DELUGE VALVE



MODEL: SD-DVH

Deluge Valve is known as a system control valve in a deluge system, used for fast application of water in a spray system. Deluge valve protects areas such as power transformer installation, storage tank, conveyor protection and other industrial application etc. With the addition of foaming agent deluge valve can be used to protect aircraft hangar and inflammable liquid fire.

SHIELD Deluge valve is a quick release, hydraulically operated diaphragm valve. It has three chambers, isolated from each other by the diaphragm operated clapper and seat seal. While in SET position, water pressure is transmitted through an external bypass check valve and restriction orifice from the system supply side to the top chamber, so that supply pressure in the top chamber act across the diaphragm operated clapper which holds the seat against the inlet supply pressure because of the differential pressure design.

On detection of fire the top chamber is vented to atmosphere through the outlet port via opened actuation devices. The top chamber pressure cannot be replenished through the restricted inlet port, and the upward force of the supply pressure lifts the clapper allowing the water flow to the system piping network and alarm devices.

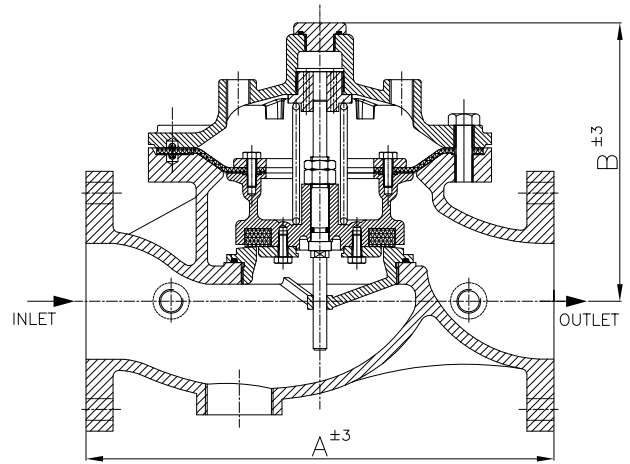

NORMAL SIZE	200,150,100, 80, 50 NB
MATERIAL	Cast Steel, Ductile Iron, Nickel Aluminium Bronze
SEVICE PRESSURE	1.4 to 17.5 Bar (20 to 250 PSI)
THREADED OPENING	BSPT
MOUNTING	Vertical or Horizontal
FLANGE CONNECTION	ANSI B 16.5 # 150 RF (FF-Optional)
FINISH	Red RAL 3000

Valve Nominal Size	'A'	'B'
200 NB	552	332
150 NB	462	282
100 NB	412	245
80 NB	372	232
50 NB	320	232

Unit : mm

CONTROL PANEL

Fire detection and control panel is a microprocessor based, application of fire alarm control system with the latest security technology, meeting the NFPA 72 A, B, C, D and E requirements. A wide variety of fictional modules are available to meet specific system needs.

SHIELD analog addressable FACP supports 2 or 4 SLC loops for a total of 500 primary points or 800 points using sub points. SLC loop communications uses standard twisted pair cabling, shielded cable is not necessary.

The panel may be configured with various communication cards; Communications options support central station monitoring, Virtual Panel, and networking. The panel can be configured as a standalone panel with just a few devices for a small building, it can also operate as the building system and can be part of a network with a total of 64 nodes serving a multiple building campus or a very large facility.



Primary	AC 230 VAC @ 2 Amps 60hz
Output	DC 24 VDC @ 4 Amps
Power Supply	5.25 Amp regulated and integrated
Charger Current	1.25 Amps max.
Finish (lid & box)	RAL3002 (Red) or BS00A05 (Gray)
Display	8 line x 40 character LCD (320 characters total)
Zones	500 Zones per network
SLC loops	2 or 4 (class A or B)
Devices per loop	126 sensors & modules (800 addresses + sub addresses max. per panel)
Dimensions	369mm x 610mm x 127mm (W x H x D)

- Multi-Loop 2 Analog Addressable Loops Field upgradable to 4.
- 126 primary points per loop.
- Powerful, network wide cause and effects (500 total).
- Fully user programmable by point or zone.
- 800 points per panel when using devices with sub points.
- Up to 10,000 ft. wiring length on SLC loop.
- 64 Panels on a network.
- Programmable through a PC connection to the panel, or through keypad.

Protecting the **Life & Property**
World Wide

SHIELD[®]
Trusted Worldwide

SHIELD FIRE, SAFETY & SECURITY LTD
Unit 3, Endeavour Drive, Basildon, SS14 3WF
Tel: +44 1708 377731 / Fax: +44 1708 347637
Email: info@shieldglobal.com, Web: www.shieldglobal.com